



Partition inserter

Our partitions inserters can be fully integrated into your lines and improve their productivity. **Compact and reliable**, our machines shape and insert economical partitions from 6 to 24 bottles with the highest accuracy and at the same time provide simple and quick format changes.

These partitions will protect the bottle only on the useful height (bigger bottle diameter). Thanks to the bottle placed in the center of the case on the inserter bottom, even when the case is put upside down, the inserter does not fall down and enables to protect the bottles.

Application : **Beverage & fragile products**

Some inserter examples

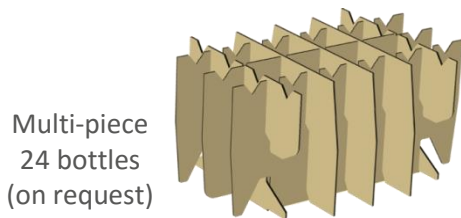
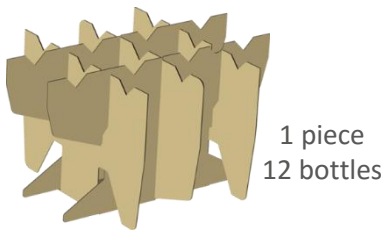

Partition inserter CRX

Principal

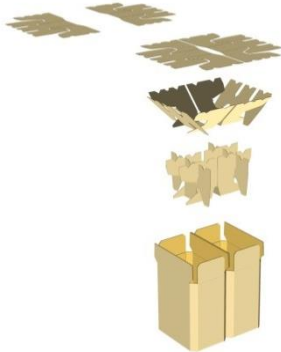

Layout

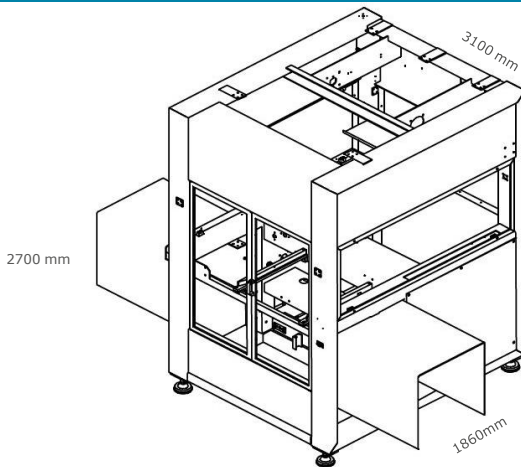

Quality

- High efficiency rate
- High-accuracy

Productivity

- Mechanical, high-performance
- No glue
- Compact machines
- Easy to set up

Flexibility

- Single-piece division for 6 and 12 bottles
- Multi-piece for 15 to 24 bottles
- Quick change over for 6 to 12 bottles (less than 1mn)

Economy

- Division made of economical cardboard
- Compact, micro flute, small or medium flute cardboard
- Low grades (100g/100g/100 g) and recycled paper
- Protect only on the useful height

Technical features

Machines	Die-cut formats (DiamXH) mm	Output maxi	Machine dim (mm)
CRX 323	Mini:55x140 Maxi: 120x200	42 c/mn	1860 x 3100 x 2700
CRX 324	Mini:75x140 Maxi: 140x240	42 c/mn	2020 x 3100 x 2650

- Format change : approx. 5 min

DS SMITH PACKAGING SYSTEMS

12 rue Gay-Lussac

ZI Dijon-Chenove

21302 Chenove

Tel: +33 (0)3 80 54 00 20

www.dssmith.com/packagingmachinery

#PackagingStrategists