

PolyDrain®

Pre-engineered Surface Drainage Manual



Streetscape Applications



Food Processing Applications



Industrial Applications

www.abtdrains.com

Today's Hydraulic Solutions



ABT, INC.

Advanced Building Technologies, Inc.

PolyDrain

ABT, Inc. manufactures PolyDrain; the standard for pre-engineered trench drains. Experienced Architects and Engineers recognize the benefits of PolyDrain for a wide variety of applications. PolyDrain polymer concrete trench drains give the specifier the precision and accuracy required to satisfy hydraulic and chemical resistant demands.

PolyDrain channels are a nominal meter (39.19 in., 3.27 ft.) long. Standard channels have a 0.6% built in slope. The 30 standard channels are positioned sequentially in numerical order from 010 to 300, creating a continuously sloped channel run. With PolyDrain, runs of almost any length are possible by varying outlet placements, integrating non-sloping channels and using PolyWall Sidewall Extensions for increased depth. Channel runs can be designed with tees and turns. These can be fabricated onsite utilizing commercial grade cutting tools.

PolyDrain® Formula

Flammability and NFPA Codes

Trench drains are often the collection point for flammable liquids and heavier than air vapor, and can contribute to the spread of fire. Selecting a trench drain with the proper material properties is critical to the life cycle of the product and life safety of a buildings inhabitants. ABT Inc's Polyester Polymer Concrete products carry the UL-723 Classified mark for Class A fire rating. Demand a UL Classified product.

PolyDrain Formulations

ABT offers two compositional formulations for PolyDrain channels, depending on the effluent and chemical environment. Both offer superior strength and durability as well as marked cost advantages over alternative materials. Standard PolyDrain channels are manufactured from PolyDyn®, an advanced formulation of selected quartz aggregates and inert mineral fillers bonded together in a high-grade polyester resin. This formulation is suitable for use in both exterior and interior applications. When a higher level of chemical resistance is required, ABT offers PolyDrain in a special formulation called PolyChampion®, which has the same quartz and mineral fillers as the PolyDyn® formulation, but with a premium grade vinyl ester resin binder. This formulation will withstand a broader range of corrosive salts, fuels, acids and alkalis.

Comparative Analysis

Fluid	PolyDyn	PolyChampion	Portland Cement
Water	✓	✓	Permeable
Gasoline	✓	✓	Permeable
Diesel Fuel	✓	✓	Permeable
Aviation Fuel	✓	✓	Permeable
Hydraulic Oil	✓	✓	Permeable
Fuel Oil	✓	✓	Permeable
Hydraulic Fluid	✓	✓	Permeable
Motor Oil	✓	✓	Permeable
Sea Water	✓	✓	Permeable
Acids		✓	Corrodes
Road Salts	✓	✓	Corrodes

Polymer Concrete is resistant to salt, oil, gas, sewage, most acids and many alkalis. This makes it excellent for chemical transport, washdown and food processing, as well as many other applications.

Physical Properties of PolyDyn® Thermoset Polyester Polymer Concrete

Property	Test Method	Value
Compressive Strength	ASTM C579	14,000 psi Minimum
Bending Strength	ASTM C580	4,000 psi Minimum
Tensile Strength	ASTM C307	2,000 psi Minimum
Moisture Absorption	ASTM D570	0.1% Maximum
Chemical Resistance	ASTM C267	Pass- Automotive Fluids
Freeze/Thaw (1600 cycles)	ASTM C666	No Weight Loss
Fungi Growth Resistance	ASTM G21	Zero Mold Growth
Flame Spread - UL/ULC	UL 723	Class A

PolyDrain Features

Pre-Sloped Radius Channels



Standard PolyDrain channels have a built-in 0.6% slope with a smooth radius bottom and a 4 inch trench width. These features provide excellent hydraulic efficiency. Without any site slope, a 3.5 feet per second self-cleaning velocity is

obtained when the channels are flowing full.

Interlocking Joints



PolyDrain channels have interlocking tongue-and-groove joints that serve two important functions. First they aid in maintaining proper channel alignment during the pour. Second, they assist in securing channel connections to prevent fluid migration out

of the system. ABT maintains a line of sealants that can be applied to channels when a sealed system is required.

Anchoring Ribs



PolyDrain channels are formed with full-length anchoring ribs on each side of the channel at the base of the side wall. These anchoring ribs provide a positive mechanical lock with surrounding concrete.

Independent Anchor Frame

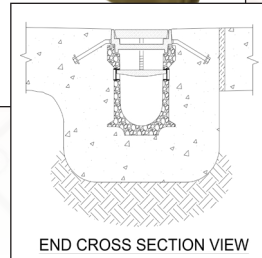

Independently anchored frames transfer the dynamic loads directly into the encapsulation concrete and channels are mechanically anchored via the full length rib. This eliminates the wheel load from creating strain on the channel and keeps the channel safely in the concrete.

PolyWall® Sidewall Extensions

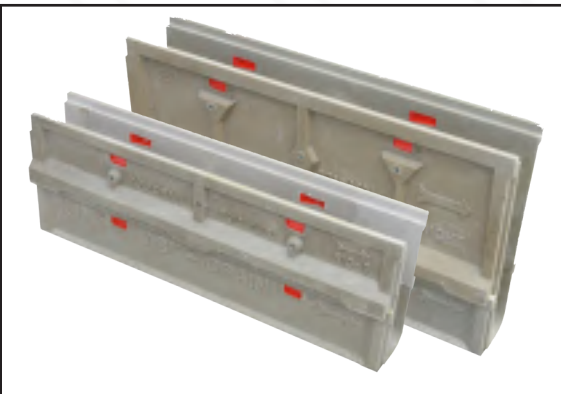

PolyWall I and II Sidewall Extensions allow the designer or contractor to extend a continuous-sloping channel run from 98.1 ft. (30 m) to 294.3 ft. (90 m) without necessity of a catch basin or outlet.

A series of specially modified channels that addresses the difficulties encountered when two sloping channels converge where a vertical outlet is required. For every outlet channel (050, 100, 150, 200, 250 and 300), a Gender Mender channel is molded with a female interlocking joint at the low point. This feature provides proper channel alignment and eliminates field fabrication for these center draining configurations.

Gender Mender Outlet Channel



PolyDrain Design

The PolyDrain Trench Drain System

The PolyDrain Trench Drain System consists of 30 interlocking sloped channels and 4 non-sloped channels. The non-sloping channels can be inserted at specified intervals in order to extend channel runs. Catch basins, horizontal outlet plates, closed end plates and vertical outlet plate adapters can be installed at designated locations. Closed end plates terminate channel runs. To determine number of channels required simply divide footage by 3.27.

PolyDrain channels are a nominal meter (39.19 in., 3.27 ft.) long. Standard channels have a 0.6% built in slope. The 30 standard channels are positioned sequentially in numerical order from 010 to 300, creating a continuously sloped channel run. With PolyDrain, runs of almost any length are possible by varying outlet placements, integrating non-sloping channels and using PolyWall Sidewall Extensions for increased depth. Channel runs can be designed with intersections or miters and fabricated onsite utilizing commercial grade cutting tools.

Channel Specifications

Use this chart to estimate flow capacities and invert elevations. Add a minimum of 4" to overall depths to estimate necessary excavation or as recommended by Structural Engineer. Actual depth of excavation is governed by slab or pavement thickness.

When using the Model 510 Series frame and grate systems, add 1.2 in. (31 mm) to the overall depths.

n=0.010

Part No.	Channel Only				Channel With PolyWall I				Channel With PolyWall II				Part No.
	Overall Channel Depth in. (cm)		Maximum Flow Rate gpm (lpm)	Weight lbs (kg)	Overall Channel Depth in. (cm)		Maximum Flow Rate gpm (lpm)	Weight lbs (kg)	Overall Channel Depth in. (cm)		Maximum Flow Rate gpm (lpm)	Weight lbs (kg)	
	Minimum	Maximum			Minimum	Maximum			Minimum	Maximum			
010	5.1 (12.9)	5.3 (13.5)	106.7 (403.8)	31.1 (14.1)	12.2 (30.9)	12.4 (31.5)	389.9 (1476.1)	82.9 (37.6)	19.3 (48.9)	19.5 (49.5)	678.3 (2567.6)	106.5 (46.3)	010
020	5.3 (13.5)	5.6 (14.1)	115.8 (438.3)	32.8 (14.9)	12.4 (31.5)	12.6 (32.1)	399.5 (1512.4)	84.6 (38.4)	19.5 (49.5)	19.7 (50.1)	687.9 (2604.1)	108.2 (47.1)	020
021	5.6 (14.1)	5.6 (14.1)	—	32.0 (14.5)	12.6 (32.1)	12.6 (32.1)	—	83.8 (38.0)	19.7 (50.1)	19.7 (50.1)	—	107.4 (46.7)	021
030	5.6 (14.1)	5.8 (14.7)	125.0 (473.1)	33.6 (15.2)	12.6 (32.1)	12.9 (32.7)	409.1 (1548.7)	85.4 (38.7)	19.7 (50.1)	20.0 (50.7)	697.6 (2640.5)	109.0 (47.4)	030
040	5.8 (14.7)	6.0 (15.3)	134.2 (508.0)	34.3 (15.5)	12.9 (32.7)	13.1 (33.3)	418.7 (1584.9)	86.1 (39.0)	20.0 (50.7)	20.2 (51.3)	707.2 (2677.0)	109.7 (47.7)	040
050	6.0 (15.3)	6.3 (15.9)	143.5 (543.0)	33.8 (15.3)	13.1 (33.3)	13.3 (33.9)	428.3 (1621.2)	85.6 (38.8)	20.2 (51.3)	20.4 (51.9)	716.8 (2713.5)	109.2 (47.5)	050
060	6.3 (15.9)	6.5 (16.5)	152.7 (578.2)	35.2 (16.0)	13.3 (33.9)	13.6 (34.5)	437.9 (1657.6)	87.0 (39.5)	20.4 (51.9)	20.7 (52.5)	726.5 (2750.0)	110.6 (48.2)	060
070	6.5 (16.5)	6.7 (17.1)	162.1 (613.5)	36.2 (16.4)	13.6 (34.5)	13.8 (35.1)	447.5 (1693.9)	88.0 (39.9)	20.7 (52.5)	20.9 (53.1)	736.1 (2786.4)	111.6 (48.6)	070
080	6.7 (17.1)	7.0 (17.7)	171.4 (648.9)	37.0 (16.8)	13.8 (35.1)	14.0 (35.7)	457.1 (1730.2)	88.8 (40.3)	20.9 (53.1)	21.1 (53.7)	745.7 (2822.9)	112.4 (49.0)	080
090	7.0 (17.7)	7.2 (18.3)	180.8 (684.3)	38.0 (17.2)	14.0 (35.7)	14.3 (36.3)	466.7 (1766.5)	89.8 (40.7)	21.1 (53.7)	21.4 (54.3)	755.4 (2859.4)	113.4 (39.4)	090
091	7.2 (18.3)	7.2 (18.3)	—	37.4 (17.0)	14.3 (36.3)	14.3 (36.3)	—	89.2 (40.5)	21.4 (54.3)	21.4 (54.3)	—	112.8 (49.2)	091
096	7.2 (18.3)	7.2 (18.3)	—	20.1 (9.1)	14.3 (36.3)	14.3 (36.3)	—	71.9 (32.6)	21.4 (54.3)	21.4 (54.3)	—	95.5 (41.3)	096
100	7.2 (18.3)	7.4 (18.9)	190.2 (719.9)	37.6 (17.1)	14.3 (36.3)	14.5 (36.9)	476.3 (1802.9)	89.4 (40.6)	21.4 (54.3)	21.6 (54.9)	765.0 (2895.9)	113.0 (49.3)	100
110	7.4 (18.9)	7.7 (19.5)	199.6 (755.5)	39.8 (18.1)	14.5 (36.9)	14.8 (37.5)	485.9 (1839.2)	91.6 (41.5)	21.6 (54.9)	21.9 (55.5)	774.7 (2932.4)	115.2 (50.3)	110
120	7.7 (19.5)	7.9 (20.1)	209.0 (791.2)	40.6 (18.4)	14.8 (37.5)	15.0 (38.1)	495.5 (1875.6)	92.4 (41.9)	21.9 (55.5)	22.1 (56.1)	784.3 (2968.9)	116.0 (50.6)	120
130	7.9 (20.1)	8.2 (20.7)	218.5 (826.9)	42.4 (19.2)	15.0 (38.1)	15.2 (38.7)	505.1 (1912.0)	94.2 (42.7)	22.1 (56.1)	22.3 (56.7)	793.9 (3005.4)	117.8 (51.4)	130
140	8.2 (20.7)	8.4 (21.3)	227.9 (862.7)	42.8 (19.4)	15.2 (38.7)	15.5 (39.3)	514.7 (1948.4)	94.6 (42.9)	22.3 (56.7)	22.6 (57.3)	803.6 (3041.9)	118.2 (51.6)	140
150	8.4 (21.3)	8.6 (21.9)	237.4 (898.6)	42.6 (19.3)	15.5 (39.3)	15.7 (39.9)	524.3 (1984.7)	94.4 (42.8)	22.6 (57.3)	22.8 (57.9)	813.2 (3078.4)	118.0 (51.5)	150
160	8.6 (21.9)	8.9 (22.5)	246.9 (934.4)	44.2 (20.0)	15.7 (39.9)	15.9 (40.5)	533.9 (2021.1)	96.0 (43.5)	22.8 (57.9)	23.0 (58.5)	822.9 (3114.9)	119.6 (52.3)	160
170	8.9 (22.5)	9.1 (23.1)	256.3 (970.4)	45.1 (20.5)	15.9 (40.5)	16.2 (41.1)	543.5 (2057.5)	96.9 (44.0)	23.0 (58.5)	23.3 (59.1)	832.5 (3151.4)	120.5 (52.7)	170
180	9.1 (23.1)	9.3 (23.7)	265.8 (1006.3)	46.1 (20.9)	16.2 (41.1)	16.4 (41.7)	553.2 (2093.9)	97.9 (44.4)	23.3 (59.1)	23.5 (59.7)	842.1 (3187.9)	121.5 (53.1)	180
190	9.3 (23.7)	9.6 (24.3)	275.4 (1042.3)	46.8 (21.2)	16.4 (41.7)	16.7 (42.3)	562.8 (2130.3)	98.6 (44.7)	23.5 (59.7)	23.7 (60.3)	851.8 (3224.4)	122.2 (53.4)	190
191	9.6 (24.3)	9.6 (24.3)	—	46.6 (21.1)	16.7 (42.3)	16.7 (42.3)	—	98.4 (44.6)	23.7 (60.3)	23.7 (60.3)	—	122.0 (53.3)	191
200	9.6 (24.3)	9.8 (24.9)	284.9 (1078.3)	46.9 (21.3)	16.7 (42.3)	16.9 (42.9)	572.4 (2166.8)	98.7 (44.8)	23.7 (60.3)	24.0 (60.9)	861.4 (3260.9)	122.3 (53.5)	200
210	9.8 (24.9)	10.0 (25.5)	294.4 (1114.4)	48.6 (22.0)	16.9 (42.9)	17.1 (43.5)	582.0 (2203.2)	100.4 (45.5)	24.0 (60.9)	24.2 (61.5)	871.1 (3297.4)	124.0 (54.2)	210
220	10.0 (25.5)	10.3 (26.1)	303.9 (1150.5)	49.8 (22.6)	17.1 (43.5)	17.4 (44.1)	591.6 (2239.6)	101.6 (46.1)	24.2 (61.5)	24.4 (62.1)	880.7 (3333.9)	125.2 (54.8)	220
230	10.3 (26.1)	10.5 (26.7)	313.5 (1186.6)	50.0 (22.7)	17.4 (44.1)	17.6 (44.7)	601.3 (2276.0)	101.8 (46.2)	24.4 (62.2)	24.7 (62.7)	890.4 (3370.4)	125.4 (54.9)	230
240	10.5 (26.7)	10.7 (27.3)	323.0 (1222.7)	51.5 (23.4)	17.6 (44.7)	17.8 (45.3)	610.9 (2312.5)	103.3 (46.9)	24.7 (62.7)	24.9 (63.3)	900.0 (3406.9)	126.9 (55.6)	240
250	10.7 (27.3)	11.0 (27.9)	332.6 (1258.9)	50.5 (22.9)	17.8 (45.3)	18.1 (45.9)	620.5 (2348.9)	102.3 (46.4)	24.9 (63.3)	25.2 (63.9)	909.7 (3443.4)	125.9 (55.1)	250
260	11.0 (27.9)	11.2 (28.5)	342.1 (1295.0)	52.4 (23.7)	18.1 (45.9)	18.3 (46.5)	630.1 (2385.3)	104.2 (47.2)	25.2 (63.9)	25.4 (64.5)	919.3 (3480.0)	127.8 (55.9)	260
270	11.2 (28.5)	11.5 (29.1)	351.7 (1331.2)	53.0 (24.0)	18.3 (46.5)	18.5 (47.1)	639.8 (2421.8)	104.8 (47.5)	25.4 (64.5)	25.6 (65.1)	929.0 (3516.5)	128.4 (56.2)	270
280	11.5 (29.1)	11.7 (29.7)	361.2 (1367.4)	54.5 (24.7)	18.5 (47.1)	18.8 (47.7)	649.4 (2458.2)	106.3 (48.2)	25.6 (65.1)	25.9 (65.7)	938.6 (3553.0)	129.9 (56.9)	280
290	11.7 (29.7)	11.9 (30.3)	370.8 (1403.6)	54.9 (24.9)	18.8 (47.7)	19.0 (48.3)	659.0 (2494.7)	106.7 (48.4)	25.9 (65.7)	26.1 (66.3)	948.2 (3589.5)	130.3 (57.1)	290
291	11.9 (30.3)	11.9 (30.3)	—	53.4 (24.2)	19.0 (48.3)	19.0 (48.3)	—	105.2 (47.7)	26.1 (66.3)	26.1 (66.3)	—	128.8 (56.4)	291
300	11.9 (30.3)	12.2 (30.9)	380.4 (1439.9)	55.6 (25.3)	19.0 (48.3)	19.3 (48.9)	668.7 (2531.2)	107.4 (48.7)	26.1 (66.3)	26.3 (66.9)	957.9 (3626.0)	131.0 (57.4)	300

Note:

- Always begin at the appropriate outlet channel, working towards the shallow end.

Notes:

- Subtract 1 in. (25 mm) from minimum and maximum depths shown to obtain invert elevations.
- Red part numbers indicate non-sloping channels.
- Hydraulic data does not have a grate locking device in flow area.
- PolyDrain systems can be extended to greater lengths by insertion of any number of non-slope channels (No. 021, 091, 096, 191, and 291) at the appropriate locations, or by the addition of PolyWall sidewall extensions.

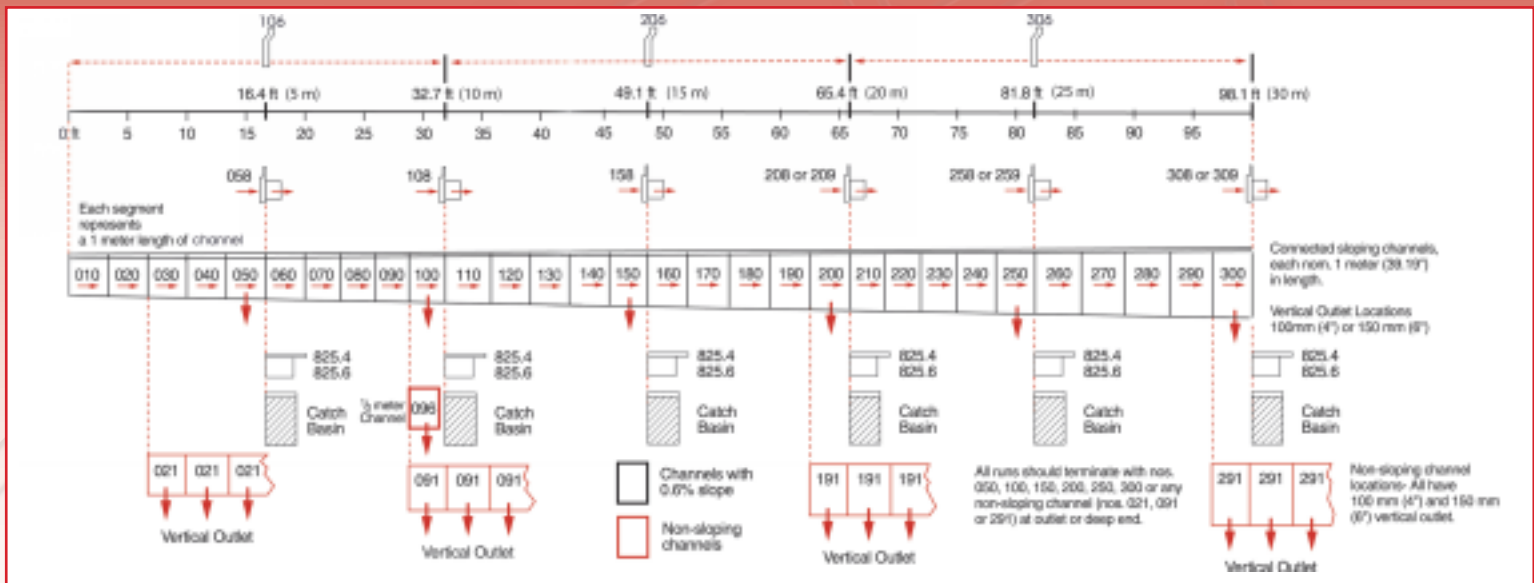

	Minimum overall depth (No. 010)	5.1 in. (128 mm)
	Maximum overall depth (No. 300)	12.2 in. (309 mm)
	Inside top width (all channels)	4.0 in. (100 mm)
	Maximum cross section flow area	39.9 sq. in. (25,400 mm ²)
	Length of slope system	98.1 feet (30 m)

Channel bottom thickness 1.0 in. (nom.) (20 mm)

PolyDrain systems can be extended to greater lengths by insertion of any number of non-slope channels (No. 021, 091, 096, 191, and 291) at the appropriate locations, or by the addition of PolyWall sidewall extensions.

39.19" or 994mm nominal 1 meter slope 0.6%

PolyWall I and II Sidewall Extensions allow the designer or contractor to extend a continuous- sloping channel run from 98.1 ft. (30 m) to 294.3 ft. (90 m) without necessity of a catch basin or outlet.

Run Variations

Neutral bottom non-sloping

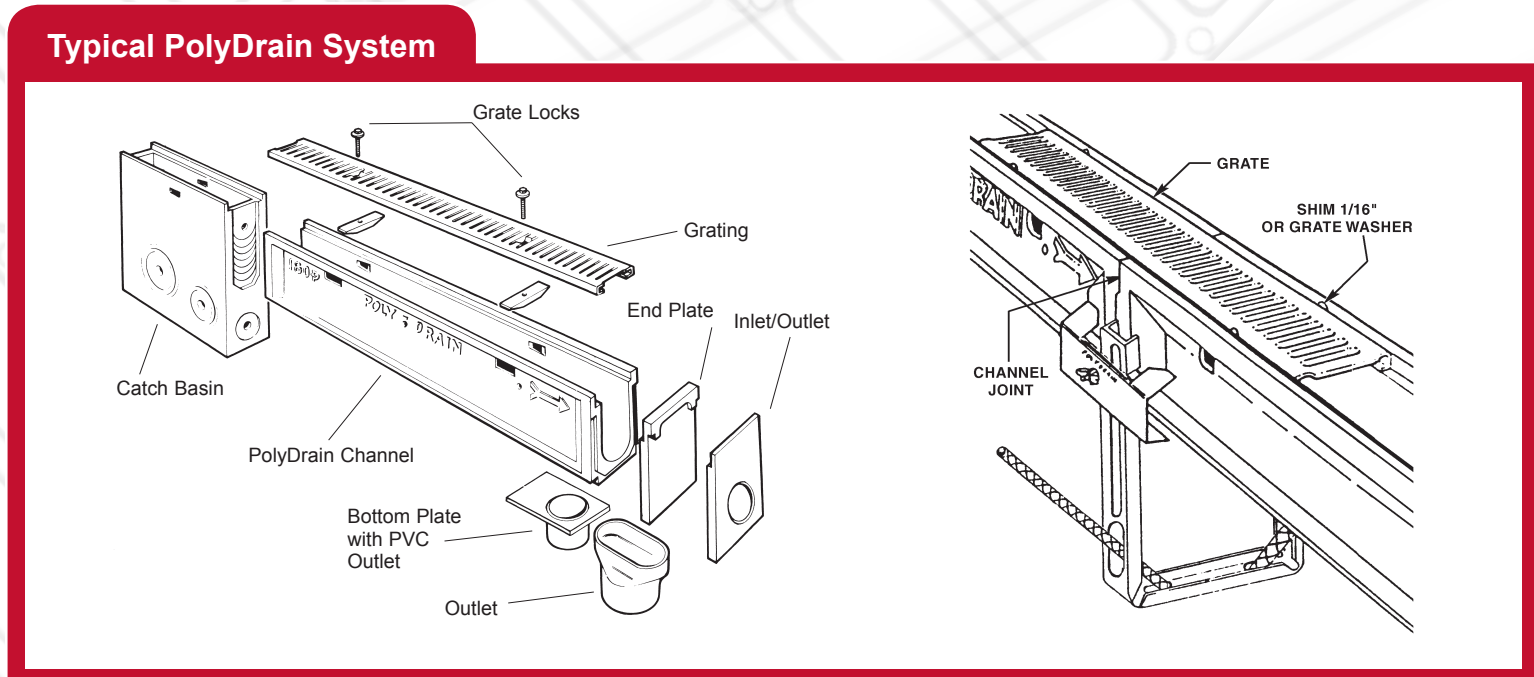

PolyDrain Grates

300 Series Thermoplastic Grates

Ornamental Thermoplastic Grates

Part No.	Material	Load Class	Length in (m)	Weight lb	Locking Device
2336	Thermoplastic "Herringbone"	A	19.60 (0.5)	1.1	2840A.25A
Stock Colors: Black Call for available colors					
2338	Thermoplastic "Longitudinal"	A	19.60 (0.5)	1.1	2840DA



2336 "Herringbone"



2338 "Longitudinal"

400 Series Stamped Grates

Solid Covers

Part No.	Material	Load Class	Length in (m)	Weight lbs	Locking Device
2404	Solid Cover, smooth	A	39.19 (1.0)	6	2810A
2406	Solid Cover, embossed	A	39.19 (1.0)	6	2810A
2444	18-8 Stainless steel, smooth	A	39.19 (1.0)	7	2840A
2446	18-8 Stainless steel, embossed	A	39.19 (1.0)	7	2840A

- above covers available in 1/2 meter lengths -



Solid Cover - Smooth



Solid Cover - Embossed

Perforated Heel-Proof Grates

Part No.	Material	Load Class	Length in (m)	Weight lbs	Locking Device
2410	Galvanized Perforated	A	39.19 (1.0)	6	2810A
2452	18-8 Stainless steel	A	39.19 (1.0)	6	2840A

- above covers available in 1/2 meter lengths -

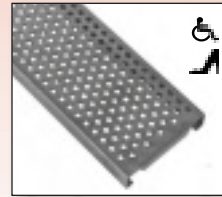

Perforated - Heel Proof



Slotted

Reinforced Perforated Heel-Proof Grates

Part No.	Material	Load Class	Length in (m)	Weight lbs	Locking Device
2412	Galvanized steel	C	39.19 (1.0)	8	2810A
2412.19	Galvanized steel, 19 stiffeners	D	39.19 (1.0)	10	2810A
2454	Stainless steel	C	39.19 (1.0)	8	2840A
2454.19	Stainless steel, 19 stiffeners	D	39.19 (1.0)	10	2840A
2486	Brass	B	39.19 (1.0)	8	2892A

- above covers available in 1/2 meter lengths -

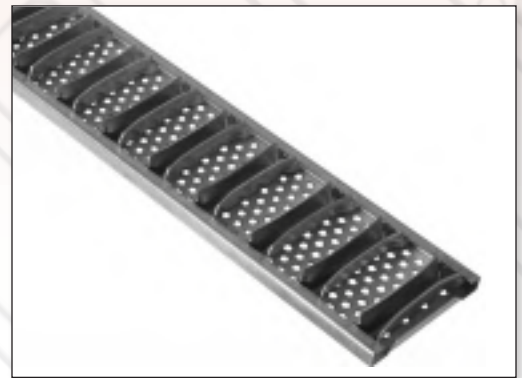

Example: Reinforced Underside

Slotted Steel Grates

Part No.	Material	Load Class	Length in (m)	Weight lb	Locking Device
2420	Galvanized steel	B	39.19 (1.0)	6	2811A
2440	Stainless steel	B	39.19 (1.0)	6	2841A
2420PG	Galvanized Steel	B	39.19 (1.0)	6	811A

- above covers available in 1/2 meter lengths -

Reinforced Slotted Steel Grates

Part No.	Material	Load Class	Length in (m)	Weight lb	Locking Device
2422	Galvanized steel	C	39.19 (1.0)	8	2811A
2422.19	Galvanized steel	D	39.19 (1.0)	8	2811A
2442	Stainless steel	C	39.19 (1.0)	8	2841A
2442.19	Stainless steel	D	39.19 (1.0)	8	2841A

- above covers available in 1/2 meter lengths -



Paver Grate



2468.SSHD End Frame

Paver Grate

Part No.	Material	Load Class	Length in(m)	Weight lbs	Locking Device
2420PG	Galvanized Steel	A	19.60 (0.5)	12	2811A
2440PG	Stainless Steel	A	19.60 (0.5)	12	2841A

- above covers available in 1/2 meter lengths -

Heavy Duty Stainless Steel Forklift System

Part No.	Material	Length in(m)	Weight lbs	Locking Device
2468.SSHD	S.S. Heavy Duty Frame & Grate	19.60 (0.5)	12	2877.SSHD

Locking Devices

Grate locking devices are recommended for all applications involving vehicular traffic, or where vandalism may be a problem. Locking devices are provided in zinc-plated, stainless steel and brass. The bolt is threaded into the lock toggle through the hole provided in the grate prior to grate installation. As the bolt is tightened, the toggle cams into place for hands-free installation.

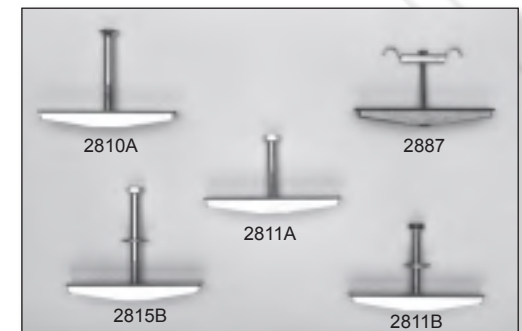

Locking Device Examples



2501



2502

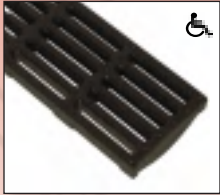

2504



2511AF

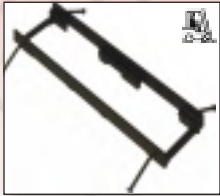

2510AF Anchor Frame



2510MFFAF End Frame



2512AF



2514AF



New! 2532B Frame and Grate



Locking Devices
PlateLock Bolt Lock Assembly

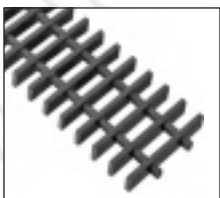

2720 -FRP



2722 -FRP

500 Series Slotted Cast Grates

Ductile Iron Solid Cover

Part No.	Material	Load Class	Length in (m)	Weight lb	Locking Device
2501	Ductile iron	G	19.60 (0.5)	12	2811B

Slotted Grates

Part No.	Material	Load Class	Length in (m)	Weight lb	Locking Device
2502	Ductile iron	E	19.60 (0.5)	8	2811B

Longitudinally Slotted Grates

Part No.	Material	Load Class	Length in (m)	Weight lb	Locking Device
2504	Ductile iron	E	19.60 (0.5)	10	2811B

2510 Ductile Iron Frames

Part No.	Material*	Length in (m)	Weight lb	Lockin Device
2510AF	Ductile Iron	19.60 (0.5)	9	N/A
2510MFFAF	Ductile iron	19.60 (0.5)	9	N/A

NOTE: One is required at each end run, one at each tee, two are required at 90° turn.

2510AF Ductile Iron Frame & Ductile Grate

Part No.	Material	Load Class	Length in (m)	Weight lb	Locking Device
2511AF	Ductile iron frame and 2501	G	19.60 (0.5)	21	2815B
2512AF	Ductile iron frame and 2502	E	19.60 (0.5)	15	2815B
2514AF	Ductile iron frame and 2504	E	19.60 (0.5)	17	2815B

New! 2530 Frame & Grate Assemblies

Part No.	Material*	Load Class	Length in (m)	Weight lb	Locking Device
2532B	Ductile iron frame and 2502	G	19.60 (0.5)	15	Per P.O.

*All ductile iron grates and frames available with galvanized coating. All ductile and cast grates have compatible anchor frames.

2700 Series FiberGlass Grates (FRP)

Part No.	Material	Load Class	Length in (m)	Weight lb	Locking Device
2720	Vinylester FRP (bars on 1" centers)	B	39.19 (1.0)	4	2887
2722	Vinylester FRP (bars on 0.6" centers)	D	39.19 (1.0)	6	2887

Vinylester Grates available in 1/2 meter

Note:

- Always use a frame when hard wheel traffic is anticipated.
- ABT recommends a frame or overlay rail if regular or frequent pneumatic traffic is expected.

Static Load Classification

Load Class	A	B	C	D	E	F	G
Description	Light Duty	Medium Duty	Heavy Duty	Extra Heavy Duty	Extreme Heavy Duty	Airport Rated	Airport Rated
Typical Application	Pedestrian	Residential	Commercial	Industrial	Highway	Regional Airport	Port/Intermodal
Category Standard Basis	Industry Standard	Industry Standard	Federal A-A60005	AASHTO H-20	AASHTO HS-25	FAA AC-150	Industry Standard
Maximum Proof Load	6,000 Lbs	12,150 Lbs	25,000 Lbs	40,000 Lbs	50,000 Lbs	100,000 Lbs	200,000 Lbs
Proof Load Pressure	75 psi	150 psi	310 psi	494 psi	620 psi	Variable	2469 psi

- ADA Compliant** - Grate's slot width does not exceed 1/2 Inch in the predominant travel direction.
- Hard Tire Rated** - TFX rails, PDX rails, and PolyDrain frames are Hard Tire Fork Lift Rated to grate and encapsulation concrete load limits.
- Heel Proof Rated** - Grate's slot width does not exceed 5/16 Inch.
- Dynamic Load Rated** - Grates, rails, frames, and grate retention are designed for 0.7g transverse and longitudinally dynamic loads.
- Airport Rated** - Designed for both large vertical and dynamic loads. Common conditions in Airport, Port, and Intermodal applications.

PolyDrain Grates

2509 Series Ornamental Ductile Iron Grates

Part No.	Material*	Load Class	Length in (m)	Weight lb	Locking Device
2506	Ductile iron "Herringbone"	E	19.60 (0.5)	7	2810A
2509	Ductile iron "Imperial Star"	D	19.60 (0.5)	10	2810A
2509A	Ductile iron "Maze"	D	19.60 (0.5)	10	2810A
2509B	Ductile iron "River Wave"	D	19.60 (0.5)	10	2810A
2509C	Ductile iron "Incan Myth"	D	19.60 (0.5)	10	2810A
2509D	Ductile iron "Rain Drops"	D	19.60 (0.5)	10	2810A
2509E	Ductile iron "Fern"	D	19.60 (0.5)	10	2810A
2509F	Ductile iron "Picaso"	D	19.60 (0.5)	10	2810A
2509G	Ductile iron "Smooth Stones"	D	19.60 (0.5)	10	2810A
2509H	Ductile iron "Ocean Current"	D	19.60 (0.5)	10	2810A
2509J	Ductile iron "Gears"	D	19.60 (0.5)	10	2810A
2509M	Ductile iron "Rain Drop" Heel Proof	D	19.60 (0.5)	10	2810A
2509N	Ductile iron "Imperial Star" HP	D	19.60 (0.5)	10	2810A

2519 Series Anchor Frame & Ornamental Grate Assemblies

Part No.	Material	Load Class	Length in (m)	Weight lb	Locking Device
2516	Ductile iron frame and 2506	E	19.60 (0.5)	16	2810AXL
2519	D.I. Frame and 2509 "Imperial Star"	D	19.60 (0.5)	19	2810AXL
2519A	D.I. Frame and 2509A "Maze"	D	19.60 (0.5)	19	2810AXL
2519B	D.I. Frame and 2509B "River Wave"	D	19.60 (0.5)	19	2810AXL
2519C	D.I. Frame and 2509C "Incan Myth"	D	19.60 (0.5)	19	2810AXL
2519D	D.I. Frame and 2509D "Rain Drops"	D	19.60 (0.5)	19	2810AXL
2519E	D.I. Frame and 2509E "Fern"	D	19.60 (0.5)	19	2810AXL
2519F	D.I. Frame and 2509F "Picaso"	D	19.60 (0.5)	19	2810AXL
2519G	D.I. Frame and 2509G "Smooth Stones"	D	19.60 (0.5)	19	2810AXL
2519H	D.I. Frame and 2509H "Ocean Current"	D	19.60 (0.5)	19	2810AXL
2519J	D.I. Frame and 2509J "Gears"	D	19.60 (0.5)	19	2810AXL
2519M	D.I. Frame and 2509M "Rain Drops" HP	D	19.60 (0.5)	19	2810AXL
2519N	D.I. Frame and 2509N "Imperial Star" HP	D	19.60 (0.5)	19	2810AXL

*All ductile iron grates and frames available Uncoated, Epoxy Coated, and Galvanized. All ductile and cast grates have compatible anchor frames.

Frame Example

2510 Ductile Iron Frame and 2509G "Smooth Stones"



2506 "Herringbone"



2509 "Imperial Star"



2509A "Maze"



2509B River "Wave"



2509C "Incan Myth"



2509D "Rain Drops"



2509E "Fern"



2509F "Picaso"



2509G "Smooth Stones"



2509H "Ocean Current"



2509J "Gears"



2509M "Rain Drops" HP

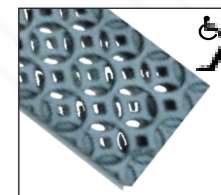

2509N "Imperial Star" HP

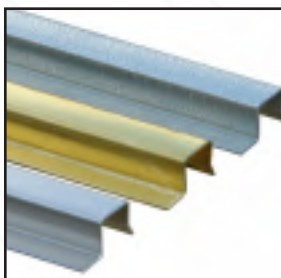

Overlay Rails

Overlay Rails are made of galvanized steel, stainless steel or brass and are applied to any standard channels. They cover and protect the channel edge in medium-duty traffic applications. When visual aesthetics are important, the Overlay Rails enhance the appearance of the PolyDrain channels. (Overlay rails for end plates are available).

PolyDrain Accessories

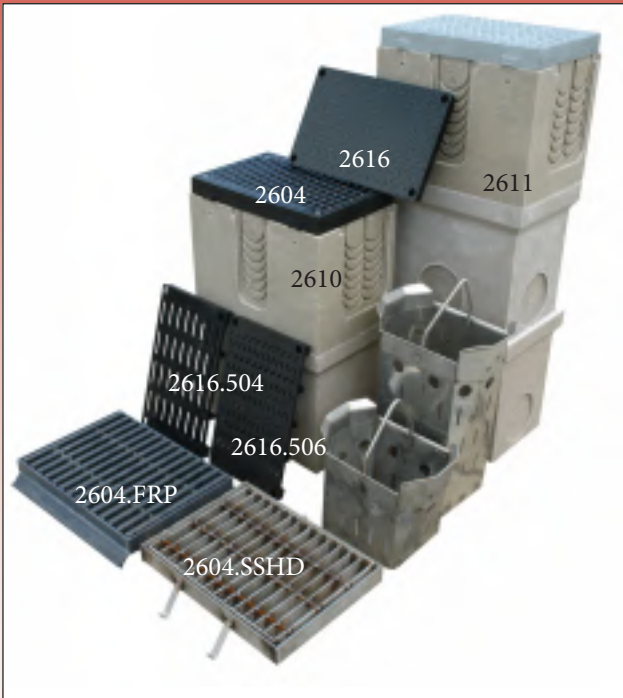

2610-2611 Large Catch Basins

PolyDrain's 2610 and 2611 Large Catch Basins are designed to accept large volumes of fluids. Removable stainless or galvanized steel trash buckets are available and a cast iron grate and frame is included. Catch basins are 19.6" long and 12.8" wide and have pre-formed cutouts for insertion of channels and 6 in. (150 mm) outlets on all four sides of the basin, although other pipe sizes can be fitted to the catch basin as required. PolyDrain Large Catch Basins have a stackable design which allows for installation to any required depth.

2600 Series Grates

Grates for 2600 Series Catch Basins

Part No.	Material	Load Class	Length in (m)
2604	Slotted Ductile iron	E	18.87 (0.48)
2616	Solid Cover- Steel	D	18.87 (0.48)
2616.506	Heelproof Herringbone	C	18.87 (0.48)
2616.504	Longitudinal Slotted	C	18.87 (0.48)
2604.SSHD	Stainless Steel	D	18.87 (0.48)
2604.FRP	Fiberglass	B	18.87 (0.48)

Inlets, Outlets, and End Caps

All 4 in. (100 mm) horizontal plates have inlet or outlet capability. As outlets, they fit the downstream end of every fifth channel, or as inlets, the upstream end of the following channel. All 4 in. (100 mm) plates are made with a PVC sleeve to accept either SCH40 or SDR35 pipe. 6 in. (150 mm) outlet plates are made with a special adapter flume. Vertical outlet plates fit over the cutouts on each of the outlet channels. 8 in. and 12 in. outlets are also available.

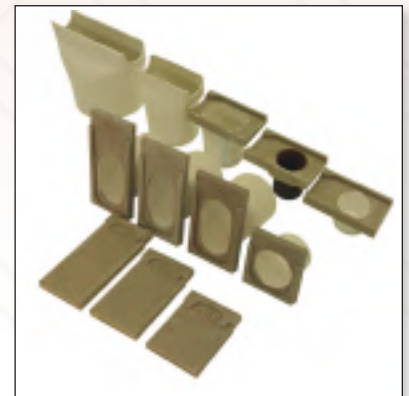

PolyDrain Shallow

PolyDrain Shallow offers a practical and economical drainage solution where slab depth restrictions dictate the necessity of a shallow channel. The Shallow features our exclusive "Red Dot" locking Blocks and can accept any standard PolyDrain grate. Special support legs attach to channel sidewalls and speed installation. Solid end plates and vertical outlet connectors are also available.

2900 Series Small Catch Basins

PolyDrain's 2900 Series Catch Basins have the same outside dimensions as standard PolyDrain channels. Designed to accept sidewall extensions, they can be positioned any place in a channel run. The 2900 Series Catch Basins are available with easy-to-remove stainless or galvanized steel trash buckets and can accept the full range of lockable inlay or frame-and-grate systems. Available with foul air traps when required.

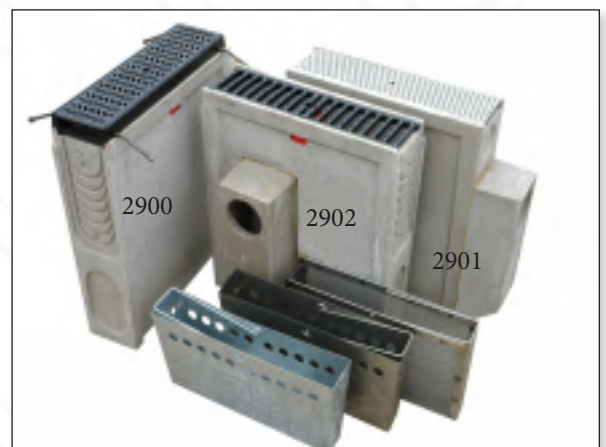

PolyDrain Accessories

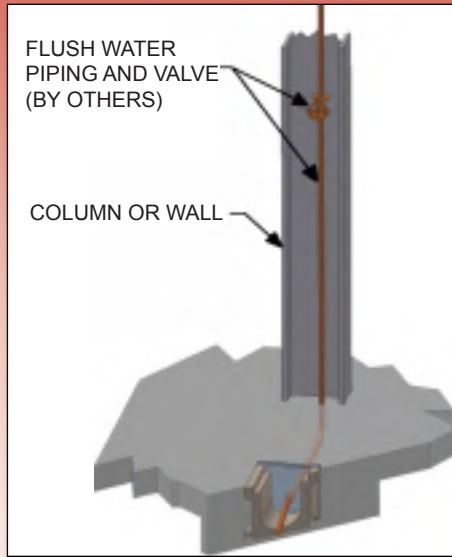

PolyJet

The PolyJet kit is an easy way to maintain trench drain systems by adding a flush water connection to the end of the trench drain run. PolyJet kits are now available consisting of an end plate, stub pipe, retainer ring, and pipe connectors. The PJ306 Kit is compatible with all size PolyDrain channels. The 306 end cap fits the deepest channel but the pipe hole is located for the shallowest depth channel. A $\text{Ø } 1/2''$ by 6" long soft copper pipe fits through the hole in the end cap and provides means to direct the flow stream for best cleaning with minimal splash. A retainer ring secures the copper pipe in place during concrete placement. Included connections are $\text{Ø } 1/2''$ NPT male, $\text{Ø } 1/2''$ NPT female, and $\text{Ø } 1/2''$ solder coupling. Remove any excess end cap length if it causes complications during installation.



Poly Seal Applicators

PolySeal 1:

A flexible one-part polyurethane in a standard caulk tube, used as a general purpose sealant for gray water applications.

PolySeal 4:

High strength chemical resistance 2 part epoxy with static mixing nozzle. It is a non-sag sealant with 5 minute set up time, ideal for automotive fluids and most cleaners.

PolySeal 5:

Fast set, high strength, epoxy used for extreme corrosive conditions. Test coupons required to verify chemical resistance for specific applications. It is recommended for sealing joints in PolyChampion installations and ideal for bonding all PolyDrain fabrications and miters. PolySeal 5 requires a static mixing nozzle.



PolyDrain Accessories

Grate Cover Tape

Grate Cover Tape is ideal for keeping the grates clean during installation. Available in 200ft rolls.



Drain Shovel Head

Polydrain Shovel Head, conforms to PolyDrain channel bottom.



Poly Clip Installation Aids

PolyClip I Installation Aids

PolyClip was developed to speed channel installation and make the joining of the channels more secure before the pour. PolyClip consists of: two special securing brackets (one for either side of the channel); a “no-float” U-shaped leg that serves to maintain proper height and keep channels from floating during the pour; and a securing bolt to keep the entire appliance attached to the channel.

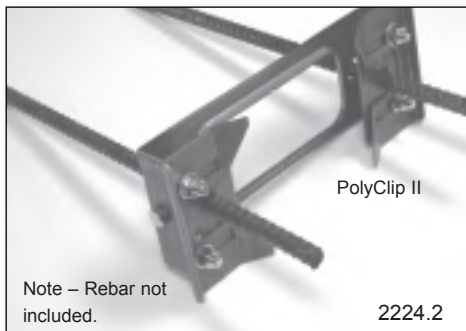

PolyClip II Installation

PolyClips are installed at the channel joints. Height adjustment is made by loosening the clamp bolt and sliding base brackets up or down on the rebar legs. Lateral and longitudinal adjustment plus retention are made by positioning and tightening adjustment clips on the top of the installation device.

PolyDrain®

Pre-engineered Surface Drainage Manual

Visit our website, www.abtdrains.com for the latest details, specifications, catalog updates

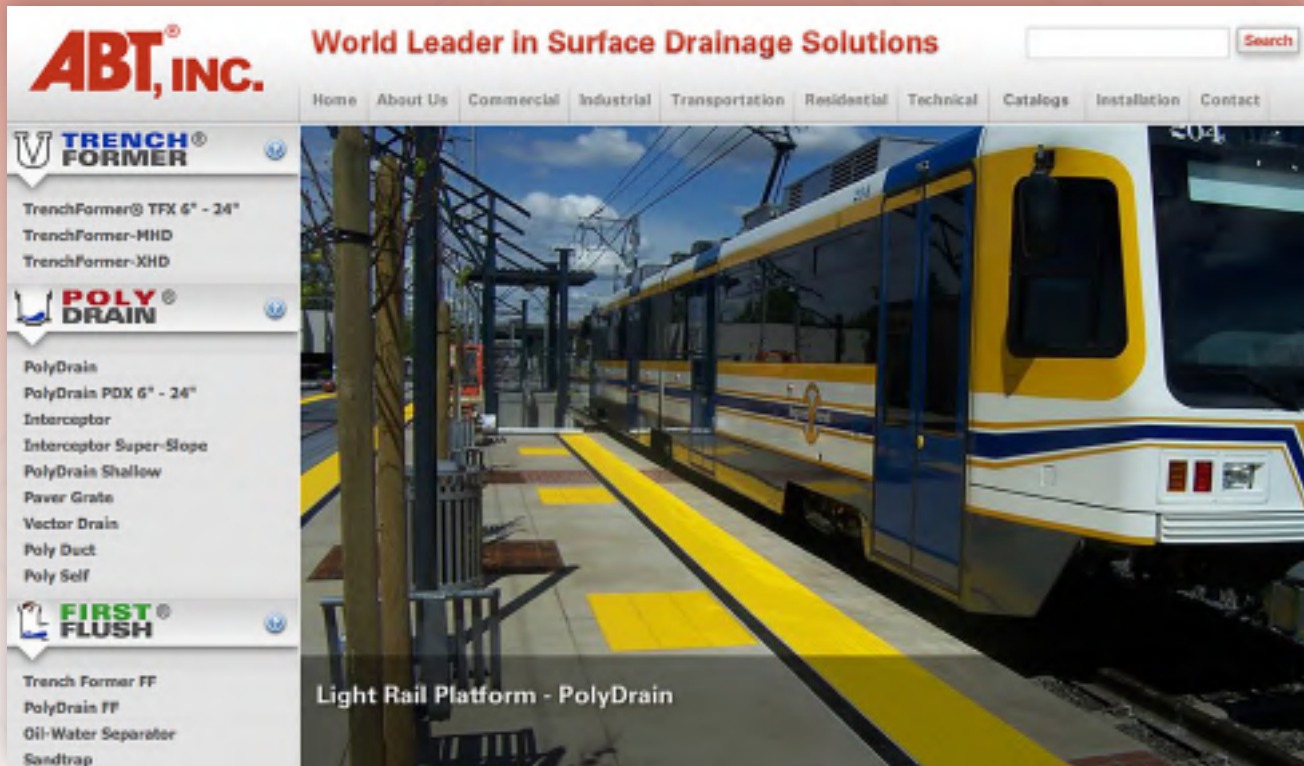

DISCLAIMER: The customer and the customer's architects, engineers, consultants and other professionals are completely responsible for the selection, installation, and maintenance of any product purchased from ABT, and EXCEPT AS EXPRESSLY PROVIDED IN ABT'S STANDARD WARRANTIES, ABT MAKES NO WARRANTY, EXPRESS OR IMPLIED, AS TO THE SUITABILITY, DESIGN, MERCHANTABILITY, OR FITNESS OF THE PRODUCT FOR CUSTOMER'S APPLICATION. Copies of ABT's standard warranties are available at www.abtdrains.com.

The information contained within is believed to be accurate but not guaranteed to be so. The customer should evaluate the suitability and safety of these products for any application. ABT assumes no liability for the end results since the conditions of installation and use are beyond the control of ABT. Concrete specifications, placement, reinforcement and structural considerations are the responsibility of the customer. ABT reserves the right to change the price, availability, specifications, and content of any of its products, literature or other information in all media at any time without notification.

PolyDrain®, PolyDyn®, PolyChampion®, GreenDot®, RedDot®, PolyWall®, TrenchFormer® are registered trademarks of ABT, Inc. USA Patent Numbers 5,281,051; 5,348,421; 5,393,171; 5,399,047; 5,573,350; 5,702,204; 5,890,839; 6,443,656; 6,533,497; 6,926,245 : Canada 2,080,136; 2,131,866; 2,131,867; 2,139,405; 2,139,407 : Mexico 189,218; 189,436; 197,851 : Other US and foreign patents pending.

ABT, INC.

Advanced Building Technologies, Inc.

PO Box 837 | 259 Murdock Road | Troutman, NC 28166

toll-free 800.438.6057 • phone: 704.528.9806 • fax: 704.528.5478

www.abtdrains.com