



## Mandrel case former

Some case examples



Centering lugs

**Accuracy, reproducibility and flexibility for your 1-piece packaging!**

Our mono-piece-mandrel case formers guarantee flexibility of use and a wide selection of packaging geometries (4, 6, 8 edges and rounded edges).

Based on our **value adding mandrel forming technology**.

They allow the forming of cases, cases with short flaps, window cases, with or without perforations and at an output rate of up to 60 cases/min.

Format changes are quick, thus leading to higher productivity. Efficiency for the global production line and secures perfect ergonomics at the work stations.

Application : **Cosmetic, dermo cosmetics, pharmacy, beverage (bottle or liquid cask), food, semi-solids & powders, homecare & chemicals.**



**#PackagingStrategists**

# Mandrel case former

## FCE 140 / 160

### Process

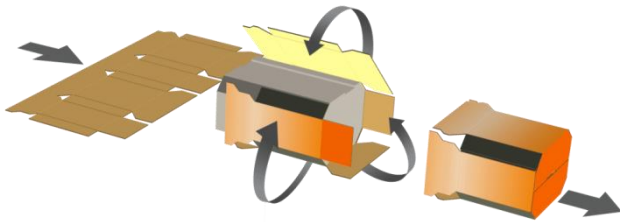

### Layout

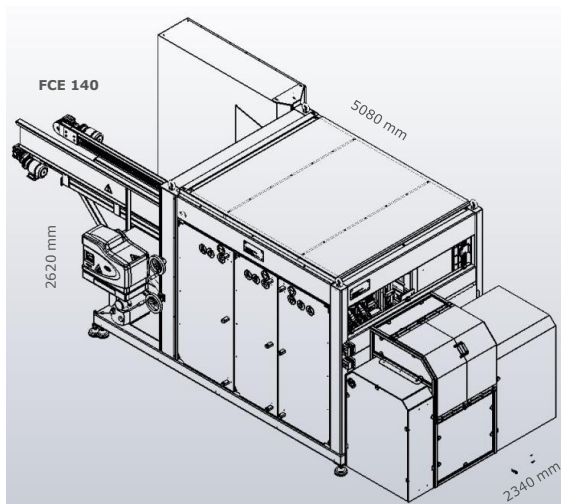

### Technical features

| Machine                                  | Inner die-cut formats (LxWxH)mm       | Output maxi                    | Machine dim (mm)   |
|--|---------------------------------------|--------------------------------|--------------------|
| FCE 140 13 S<br>FCE 140 6S<br>FCE 140 3S | Mini: 120x85x100<br>Maxi:400x300x390  | 60 c/mn<br>40 c/mn<br>30 c/ mn | 5080 x 2340 x 2620 |
| FCE 160                                  | Mini: 280x180x140<br>Maxi:460x350x420 | 55 c/mn                        | 6300 x 2300 x 2620 |

- Format change : approx. 15 min

### Main Features

- Precision Case Forming around a mandrel
- Technology providing savings along the whole end of line process
- Servo motion
- Machine accessibility
- Full speed range coverage ( up to 60 cases/min)

### Benefits

- Case perfect square up and consistency
- Quick change over
- High efficiency rate
- Lower scrap ratio

### Packaging Optimization

- Wide selection of innovative packaging shapes
- Transport packaging and / or SRP/RRP
- Wide format range
- Lower board grade and smaller surface area
- Ability to run all type of flutes

### Machine

- Low maintenance costs
- Reduced storage footprint
- Delivery of flat bed die-cut = less waste, logistic saving
- Diverse flexible options (magazine length, gluing device; fixed or semi adjustable mandrel..)

### Brand image enhancement

- Innovative design on shelves => bag-in-box with 4 or 8 sides or round corners
- +15% of communication surface with 8 sides boxes

### DS SMITH PACKAGING SYSTEMS

12 rue Gay-Lussac

ZI Dijon-Chenove

21302 Chenove

Tel: +33 (0)3 80 54 00 20

[www.dssmith.com/packagingmachinery](http://www.dssmith.com/packagingmachinery)