

CORKER

The corker/capsuling unit is built on a C shape structure. All the bottle holder strength (up to 500 kg for crown capsuling) is fully absorbed by the capsuling unit structure not by the machine body.

This strength enables multi capsuling :

- one single position column (COMET 1000 & 2000) : by disassembling - reassembling
- 3 position column: Up to 3 different capsuling units can be fitted (COMET 2000 M & 3000) : by simple turning of the column.

■ Corker unit :

4 stainless steel jaws fitted on a housing, **removable without any tools.**

This feature enables an easier cleaning, a more efficient lubrication and more regular checkups. The new cam shape assures a slower mechanical cork clamping (pictures a+b).

The electronic control of corking cycles gives a **revolutionary** flexibility in corking processes. Each cycle is divided as below :

- Clamping
- Driving-in
- Bottle unloading

A steady speed for the first two phases and a compensate speed for the third phase according to the machine layout. Example :

- the driving-in at 1000 b/h and 3000 b/h is the same
- the operator can adjust the settings according to the various types of corks: natural, agglomerate, plastic.....

The new cork conveyor operates at a **linear** motion up to 3000 b/h.

The new cork dispenser contains more than 1500 corks and limits cork dust due to a soft synchronised mixing and a punched stainless steel sheet. The cork supply can be done with the use of our cork lifter (option).

■ Other capsuling :

Various cap systems can be fitted on COMET NG :

● Screw cap capsuling :

The capsules are rolled with a 4 roller unit ZALKIN 104 fitted with a "no cap-no roll system". The rotating and the descent speed are synchronised with the machine layout.

A vibrating pot fitted on an outer stand supplies caps.

● Crown cap:

The new dispenser allows more than 3000 caps. The crimping is adjustable to comply with each cap quality.

● Plastic Headed Cork :

A vibrating pot supplies any possible plastic headed natural corks or plastic corks.

● Other Caps :

DAN monomaterial cap
ROPP cap
Etc....

■ Comfort of uses :

The operator comfort has been improved. The height and level adjustments are electrically assisted.

The machine is fitted with variable speed controllers

The control panel is an ergonomic and a simple soft keys keyboard.

A **digital display** with 4 lines offers a wide range of information :

- machine layout
 - a counter (total, daily) and a count down
 - the tank level
 - the temperature of the liquid in the tank
 - all possible defaults (for maintenance) (picture c).
- Function keys allow to adjust the corking cycle.

Les touches de fonction permettent la programmation des séquences de bouchage.

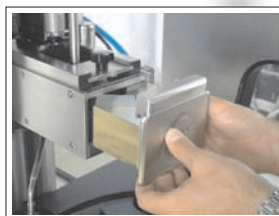

a. Corking head

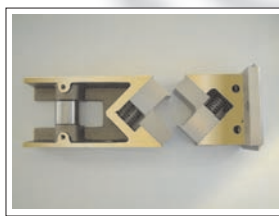

b. Stainless steel corking jaws



c. Control panel keyboard

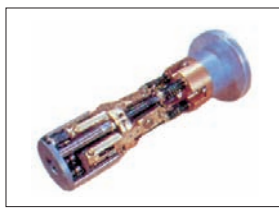

d. Screw capper

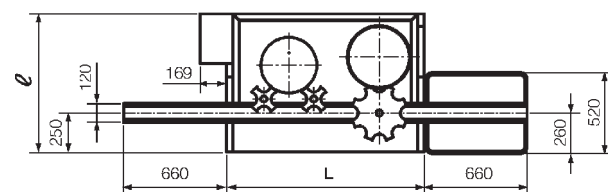
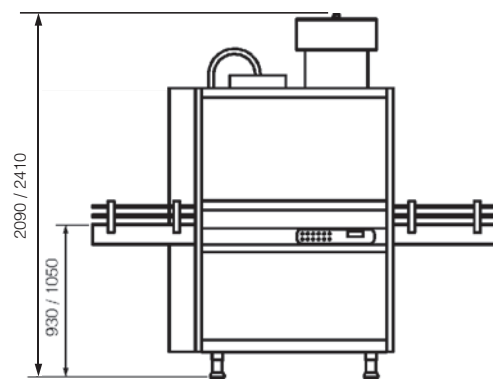

SERVICES

Our Design Department

can help our customers in their new projects by:

- supplying the drawings of our machines
- setting up the machines in your new premises or in an existing line
- studying special requirements:
- special liquids (viscosity, CO2 rate, temperature...)
- special bottle shapes
- special caps
- finding solutions to any other needs in matter of operating the machines, cleaning, sterilizing process...

Our Maintenance department

will supply any information needed and will inform about the availability of any components.

On your requirement

we will give you the address of our nearest representative.

Technical characteristics

Model	1000	2000	2000 M	3000	3200
Spouts	8	11	11	14	16
Corking colums	single	single	revolving	revolving	revolving
Layout BPH (0,75 l)	1400	2200	2200	3000	3500
Cross length	2590	2590	2955	2955	3045
Body length L	1270	1270	1635	1635	1725
Width e	890	1005	1005	1140	1230
Weight kg	900	950	1020	1100	1200

	mm
Bottle height : h	180 - 380
Bottle diameter : D	50 - 115
Neck inner diameter : d	18 - 20
Level height : n	10 - 80
Cork height : h'	35 - 54
Cork diameter : d'	23 - 26

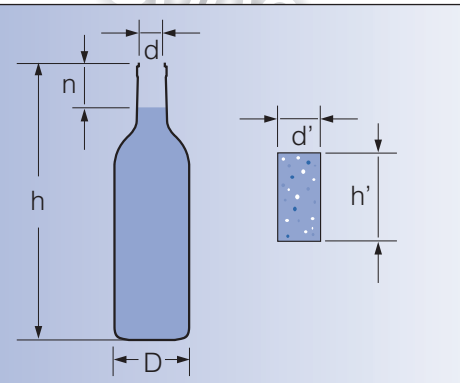

COSTRAL S.A.

Z.A. Rue des prés • F 68340 Riquewihr

Tél. + 33 (0) 3 89 47 89 45 • Fax + 33 (0) 3 89 47 81 92

E-Mail: info@costral.fr



Your Local representative :

Not contractual documents, the manufacturer reserves all rights to make modifications without notice.



Automatic bottling machine

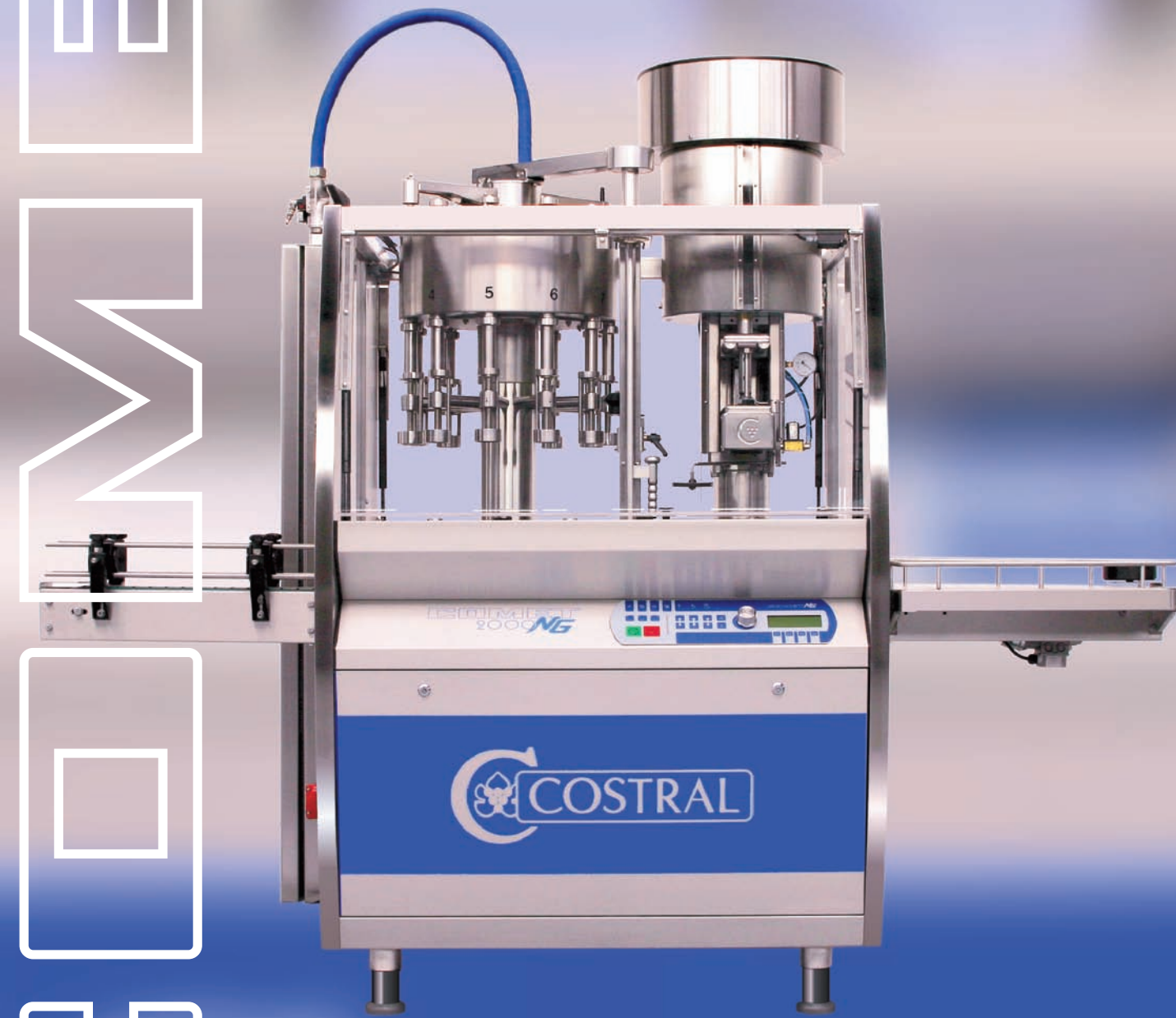

COMET 1000 NG
COMET 2000 NG
COMET 3000 NG
COMET 3200 NG



©11-04 Design: c.b.w@wanadoo.fr

1000 2000 3000 3200



The new monobloc COMET is really turning towards the technologies of the future

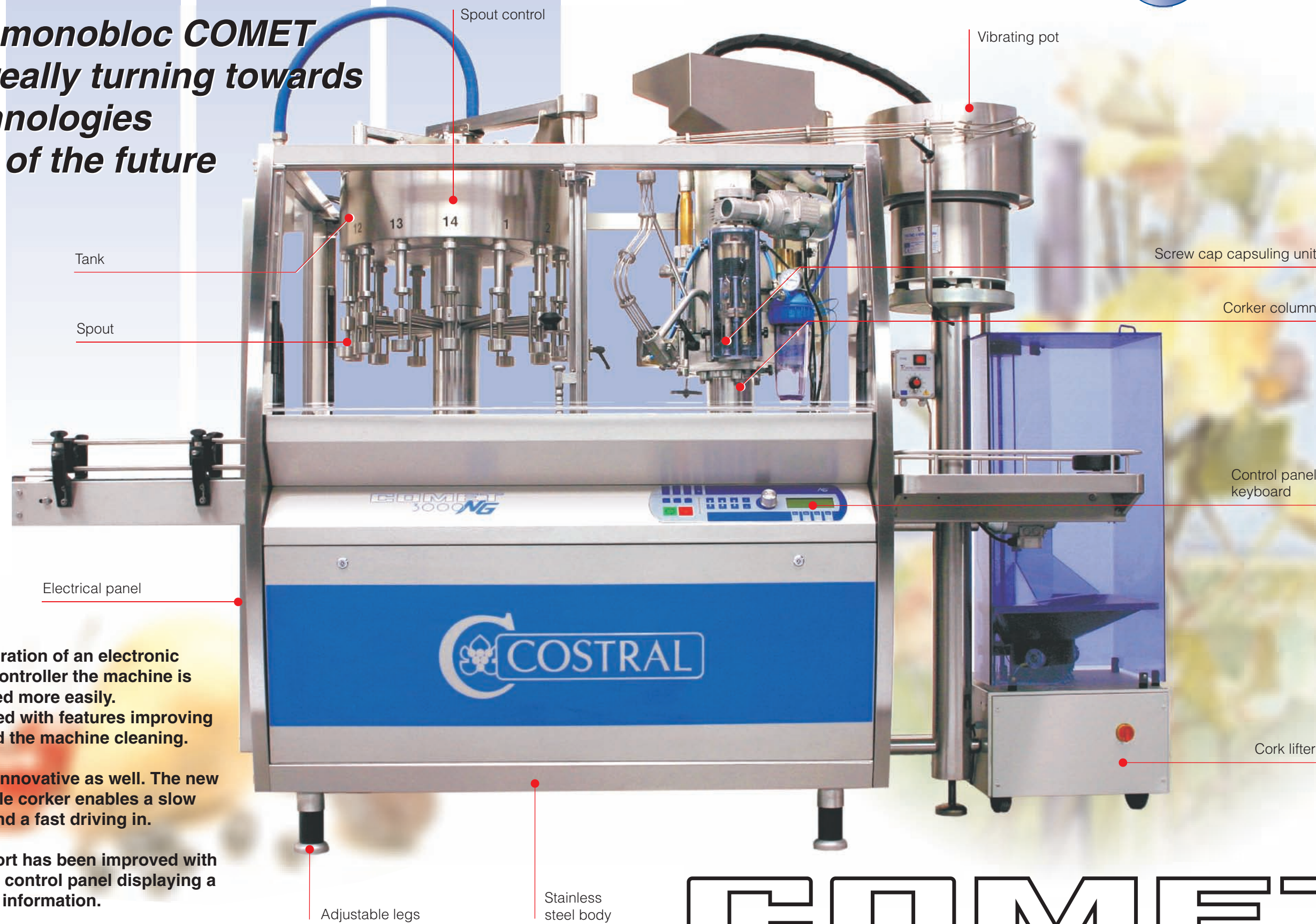

COMET NG

With the integration of an electronic programmable controller the machine is operated more easily. The filler is equipped with features improving adjustments and the machine cleaning. The corker unit is innovative as well. The new easily dismantlable corker enables a slow clamping and a fast driving in. The operator confort has been improved with the design of a new control panel displaying a lot of information.

NG Nouvelle génération • NG Neue Generation • NG New generation • NG Nueva Generación

FILLER :

The filler COMET operates on the light vacuum principle. It enables to embottle cool or warm liquids: wines, fruit juices, alcohols, vinegar, water. All the parts in contact with the liquid are made of **stainless steel 316 L**, guaranteeing a better cleaning and maintenance. The machine body is made of stainless steel 304L. The filler carousel is held on a structure welded on the lower body assuring an exceptional strength and rigidity. The pressure of the bottle holders is absorbed by stainless steel shafts fixed on the filler column. In consequence there is no strength on the spouts. This setting enables an easy spout dismantling.

External spout controller:

This is the originality of this filler. It's realised with a small rotating feature. (picture 1)

- this feature is located on the top tank at the spout top end
- opens and closes every spout with a long inner pipe enabling an air return

3 possible positions:

- 1 Filling :**
spout opened - air return opened
- 2 Levelling :**
spout closed - air return opened
- 3 Wait :**
spout closed - air return closed

On position 3 **there is no air sucking** when there is no bottle :

- between the moment a full bottle is unloaded and an empty bottle is loaded
- when there is no bottle

It's a great advantage regarding the liquid contamination by the ambient air.

Levelling valve :

Each spout is set with a levelling valve. This valve is controlled with an outer roller positionned just after the mechanical spout closure. The excess of liquid or foam is sucked by the inner air return pipe because of the light vacuum. Just after the levelling, the spout controller stops the air return and the bottle is unloaded.

Centralised levelling :

Precise level adjustments are possible while operating the machine.

The level precision is guaranteed :

- whatever the bottle heights
- whatever the numbers of operating spouts :

if only one bottle is being filled at a time the levelling is still effective.

Filling until the last drop :

The top liquid entrance enables:

- a filling until the last drop
- a very easy dismantling: the tank cover can be easily moved (picture 2). The tank is just seated on the main filler column. The level of liquid is controled with a float integrating an empty tank security and an internal thermometer. The tank level probe controls a pneumatical valve in case of gravity filling or an electric socket in case of filling with another pump.

Removable air return pipe :

The spouts are very simple. The only part in contact with the liquid is the inner air return pipe. The pipe can be easily removed by a simple manual pressure on the upper spout control (picture 3).

Sterilisation :

The chemical or thermal cleansing is done while the machine is operating. A simple removable shaft and roller controls the cleaning process.

A probe assures the tank cleaning.

At the end of the sterilisation process a simple manoeuvre on the removable shaft enables to get the machine back in the operating mode.



1 Spout control star



2 Liquid entrance with float and cleaning device



3 Disassembled spout