

# OENOFLOW™ PRO XL-S CROSSFLOW MICROFILTRATION SYSTEM

## DESCRIPTION:

Oenoflow PRO XL-S System

The Oenoflow PRO XL-S systems are specifically designed to meet the needs and requirements of mid-sized wineries. Clarification is achieved in a single process step without the need for filter aids, centrifugation or significant impact on the organoleptic characteristics of the wine. By increasing yields, reducing waste volumes and maintaining more consistent filtrate quality, the fully automated systems provide a cost saving sustainable alternative to traditional wine clarification methods.

The systems utilize Pall's proven hollow fiber membranes with unique mechanical strength and excellent chemical resistance which allow high productivity and repeated exposure to aggressive cleaning regimes. The large surface area modules enable manufacture of compact systems with low water and chemical consumption in line with winery conservation programs.

The Oenoflow PRO XL-S system utilizes Pall's proprietary Optimizer algorithm that analyzes production data and automatically adjusts operating parameters in real time to maximize system efficiency. This feature can deliver significant savings in operating expense (OPEX). The system is connected to Pall servers which allows the user easy access to their data through Pall's Oenoflow PRO app or browser portal.

With adjustable operating cycles, Pall's proprietary Low Concentration Volume (LCV) option, and automatic chemical dosing, the Oenoflow PRO XL-S system is the smart solution for reliable and economical wine clarification. Additionally the small batch program provides the flexibility required by most modern wine cellars, packagers and mobile bottlers.

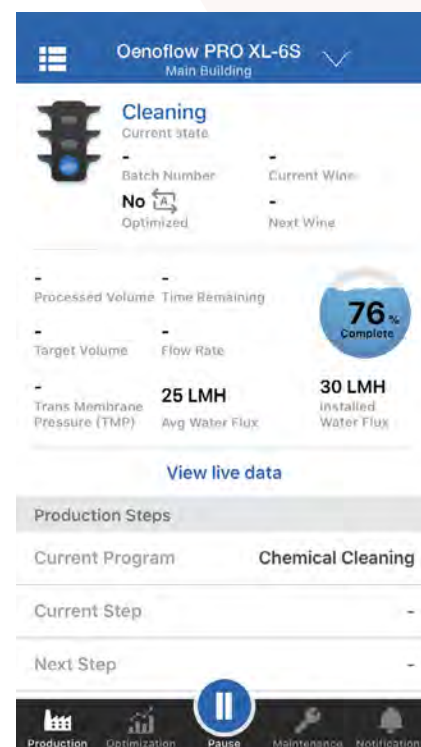
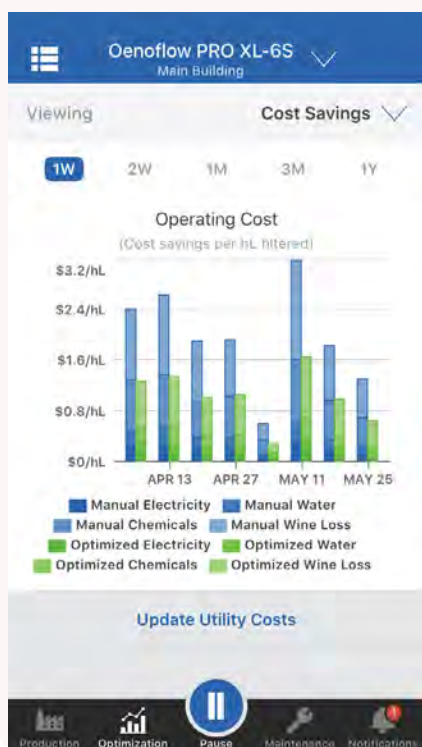
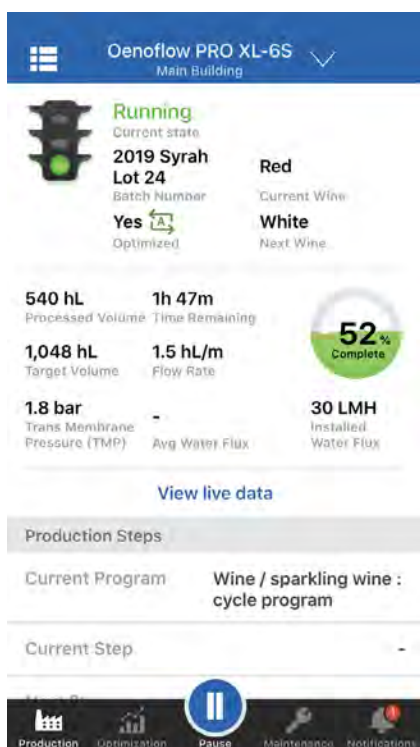

# OENOFLOW™ PRO XL-S CROSSFLOW MICROFILTRATION SYSTEM

## COST SAVING BENEFITS

The Oenoflow PRO XL-S systems incorporate unique features which enable wineries to perform clarification at low operating costs while maintaining wine quality. These include:

- PVDF membranes with high mechanical strength for longer service life
- Optimizer algorithm to minimize OPEX
- High area, high flow modules for more compact and more economical systems
- Back pulse capability for increased system productivity
- Transparent module housings to confirm filtrate quality and enhance troubleshooting capabilities
- Fully automated, customizable working cycles for unattended operation and reduced labor and downtime
- On board concentration tank with wine transfer pump for operation independent of winery conditions
- Proprietary Low Concentration Volume (LCV) option for high wine yield
- Small batch program isolating 1 module for efficient processing of batches up to 1000 L
- Water “solo” back flushes for highly effective solids removal
- Automated chemical dosing for safe and easy cleaning
- CIP system with 1 micron, 30 inch water filter and temperature control
- Automatic chemical dosing with 3 supply inlets
- Touch screen PLC
- Pressure, temperature and dry run protection
- A power jack for an external transfer pump

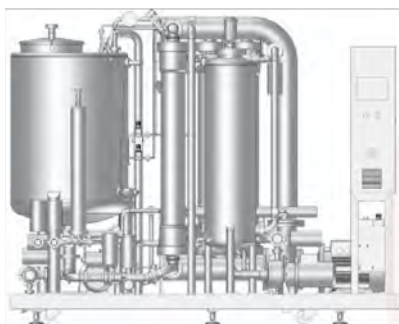

Front View



Left Side View

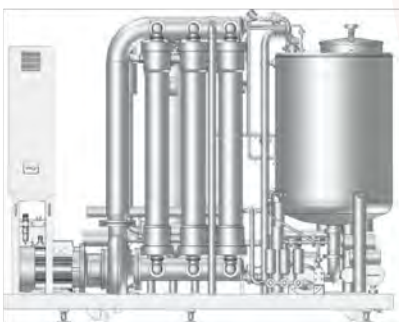

Rear View



Right Side View

## OENOFLOW PRO XL-S STANDARD COMPONENTS

The Oenoflow PRO XL-S systems are fully automated, modular systems available with 3 up to 6 crossflow filtration modules. All metal wetted parts are 304 Stainless steel. The piping manifold, membranes, pumps and instruments are mounted on a mobile frame which includes the following:

- Stainless steel pre-filter screen for large particles
- On board concentration/cleaning tank
- Feed pump
- Circulation pump
- Filtrate reservoir
- Filtrate/back flush pump
- Magnetic flow meter with batch control

## OENOFLOW XL MEMBRANES

The Oenoflow PRO XL-S modules incorporate Pall's proven symmetric hollow fiber membranes. The large diameter, high flow modules with 21.5 square meters of filter area, have at least twice the filter area of typical competitive hollow fiber modules. The module components include:

Membrane:	PVDF
Potting:	Epoxy resin
Sleeve:	Polypropylene
Housing:	Transparent polysulfone
Seals:	Ethylene Propylene copolymer

## OENOFLOW PRO XL-S STANDARD OPTIONS

The following options are available for additional supply:

- Low Concentration Volume (LCV)
- Nitrogen purge and blanketing
- Spray ball kit for T1
- External bleed
- Manual dual pre-filter screens
- External transfer pump<sup>1</sup>
- Tele-service adaptor
- Stainless steel dummy modules for future expansion capacity
- High Pressure (HP) option for treatment of sparkling wine under isobaric conditions
- Conductivity meter

<sup>1</sup> This option is supplied as an external equipment option mounted on its own mobile frame.

# OENOFLOW™ PRO XL-S CROSSFLOW MICROFILTRATION SYSTEM

## COMPLIANCE

Oenoflow PRO XL-S systems are CE to demonstrate compliance with relevant regulations including the European Pressure Directives.

Various Oenoflow modules have been qualified for compliance to specific regulatory standards for products coming into contact with foodstuffs. Please contact Pall for details.

## OPERATING CONDITIONS

### Wine Filtration

Inlet pressure: 0.5 bar to 3.5 bar (7 psi to 50 psi)

Temperature: -4 °C to 25 °C (24 °F to 77 °F)

Maximum temperature for cleaning: 65 °C (150 °F)

## STANDARD FILTRATION SKID SPECIFICATIONS

MODEL	# OF MODULES	FILTER AREA (M <sup>2</sup> )	AVERAGE FLOW RATE <sup>2</sup>	LENGTH	WIDTH	HEIGHT	WEIGHT	PRICE
Oenoflow XL-4S	4	86	40-60 hl/h (850-2000 gph)	2.70 m (8.86 ft)	1.20 m (3.94 ft)	2.15 m (7.05 ft)	1550 kg (3417 lbs)	\$189,000
Oenoflow XL-6S	6	129	60-90 hl/h (1200-2300 gph)	3.00 m (9.84 ft)	1.20 m (3.94 ft)	2.15 m (7.05 ft)	1690 kg (3725 lbs)	\$220,000

<sup>2</sup> The flow rates for the various Oenoflow XL models are averages for the complete filtration cycle, and dependent on the wine characteristics and pre-treatment.

# OENOFLOW™ PRO XL-A CROSSFLOW MICROFILTRATION SYSTEM

## DESCRIPTION

The Oenoflow PRO XL-A systems are specifically designed to meet the needs and requirements of large wineries and bottlers. Clarification is achieved in a single process step without the need for filter aids, centrifugation or significant impact on the organoleptic characteristics of the wine. By increasing yields, reducing waste volumes and maintaining more consistent filtrate quality, the fully automated systems provide a cost saving sustainable alternative to traditional wine clarification methods.

The system utilizes Pall's proven hollow fiber membranes with unique mechanical strength and excellent chemical resistance which allow high productivity and repeated exposure to aggressive cleaning regimes. The large surface area modules enable manufacture of compact systems with low water and chemical consumption in line with winery conservation programs.

The Oenoflow PRO XL-A system utilizes Pall's proprietary Optimizer algorithm that analyzes production data and automatically adjusts operating parameters in real time to maximize system efficiency. This feature can deliver significant savings in operating expense (OPEX). The system is connected to Pall servers which allows the user easy access to their data Data Sheet FBDSOENOPROXLAEN through Pall's Oenoflow PRO app or browser portal.

Oenoflow PRO XL-A System



With customizable operating cycles, process trend recording and a wide range of options, the Oenoflow PRO XL-A system offers an advanced solution with the flexibility required in most modern wine cellars, custom crush and bottling operations.

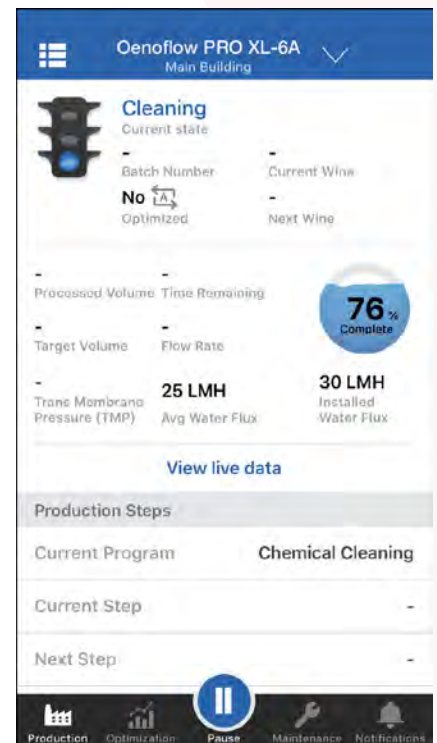
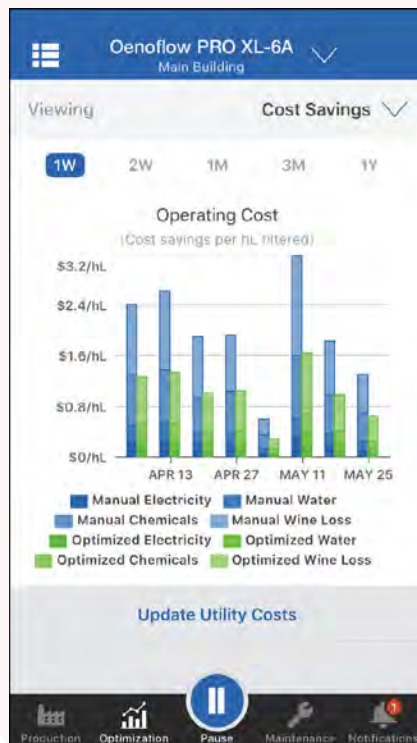
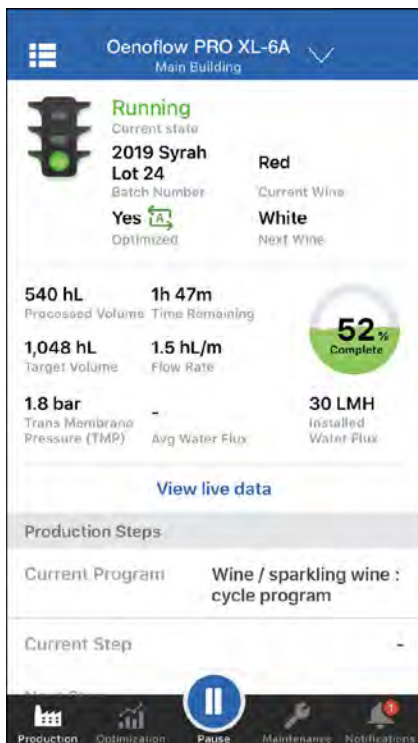

# OENOFLOW™ PRO XL-A CROSSFLOW MICROFILTRATION SYSTEM

## COST SAVING BENEFITS

The Oenoflow PRO XL-A systems incorporate unique features which enable wineries to perform clarification at low operating costs while maintaining wine quality. These include:

- PVDF membranes with high mechanical strength for longer service life
- Optimizer algorithm to minimize OPEX
- High area, high flow modules for more compact and more economical systems
- Back pulse capability for increased system productivity
- Transparent module housings to confirm filtrate quality and enhance troubleshooting capabilities
- Fully automated, customizable working cycles for unattended operation and reduced labor and downtime
- On board concentration tank with wine transfer pump for operation independent of winery conditions
- Proprietary Low Concentration Volume (LCV) option for high wine yield
- Automated chemical dosing for safe and easy cleaning
- Frequency controlled pumps for automatic flow or pressure controlled operation
- Process trend recording for monitoring and optimizing filtration performance and troubleshooting to their data Data Sheet FBDSOENOPROXLAEN through Pall's Oenoflow PRO app or browser portal

With customizable operating cycles, process trend recording and a wide range of options, the Oenoflow PRO XL-A system offers an advanced solution with the flexibility required in most modern wine cellars, custom crush and bottling operations.

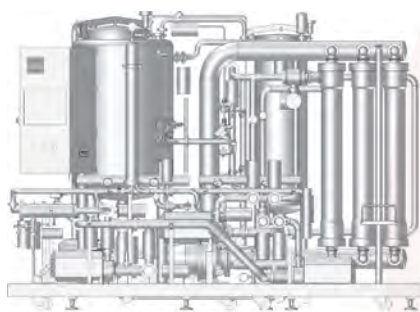

Front View



Left Side View

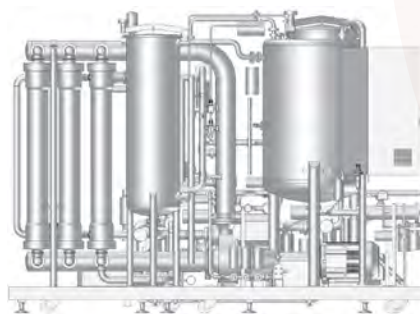

Rear View



Right Side View

## OENOFLOW PRO XL-A STANDARD COMPONENTS

The Oenoflow PRO XL-A systems are fully automated, modular systems available with 5 up to 18 crossflow filtration modules.

All metal wetted parts are 304 Stainless steel. The piping manifold, membranes, pumps and instruments are mounted on a mobile frame which includes the following:

- Transfer pump with stainless steel cover for incoming
- wine supply
- Stainless steel pre-filter screen for large particles
- On board concentration/cleaning tank with spray ball
- Feed pump with stainless steel cover
- Circulation pump
- Filtrate reservoir
- Filtrate/back flush pump with stainless steel cover
- Magnetic flow meter with batch control
- CIP system with 1 micron, 40 inch water filter and temperature control
- Automatic chemical dosing with 3 supply inlets
- Color touch screen with process flow diagram and trend recording
- Modem for quick and easy tele-service
- Conductivity meter

## OENOFLOW PRO XL-A STANDARD OPTIONS

The following options are available for additional supply:

- Low Concentration Volume (LCV)
- Tank Distribution System (TDS) for 3 inlets and 3 outlets
- Nitrogen purge and blanketing
- Automatic dual pre-filter screens
- Extra large water filtration assembly (3 cartridges)
- Analog turbidity meter
- Sanitary sampling valve
- 4th chemical supply inlet
- External bleed
- Illuminated sight glass
- Dummy modules for future expansion capacity
- High Pressure (HP) option for treatment of sparkling wine under isobaric conditions
- Spare parts package

# OENOFLOW™ PRO XL-A CROSSFLOW MICROFILTRATION SYSTEM

## OENOFLOW XL MEMBRANES

The Oenoflow PRO XL-A modules incorporate Pall's proven symmetric hollow fiber membranes. The large diameter, high flow modules with 21.5 square meters of filter area, have at least twice the filter area of typical competitive hollow fiber modules. The module components include:

Membrane: PVDF  
 Potting: Epoxy resin  
 Sleeve: Polypropylene  
 Housing: Transparent polysulfone  
 Seals: Ethylene Propylene copolymer

## COMPLIANCE

Oenoflow PRO XL-A systems are CE to demonstrate compliance with relevant regulations including the European Pressure Directives.

Various Oenoflow modules have been qualified for compliance to specific regulatory standards for products coming into contact with foodstuffs. Please contact Pall for details.

## OPERATING CONDITIONS

### Wine Filtration

Inlet pressure: 0.5 bar to 3.5 bar (7 psi to 50 psi)  
 Temperature: -4 °C to 25 °C (24 °F to 77 °F)  
 Maximum temperature for cleaning: 65 °C (150 °F)

## STANDARD FILTRATION SKID SPECIFICATIONS

MODEL	# OF MODULES	FILTER AREA (M <sup>2</sup> )	AVERAGE FLOW RATE <sup>1</sup>	LENGTH	WIDTH	HEIGHT	WEIGHT	PRICE
Oenoflow XL-8A	8	172	80-120 hl/h (2115-3170 gal/g)	3.65 m (11.97 ft)	1.85 m (6.07 ft)	2.45 m (8.04 ft)	2480 kg (5465 lbs)	\$295,000
Oenoflow XL-10A	10	215	100-150 hl/h (2640-3960)	3.90 m (12.77 ft)	1.85 m (6.07 ft)	2.45 m (8.04 ft)	2570 kg (5665 lbs)	Contact us
Oenoflow XL-12A	12	258	120-180 hl/h (3170-4755 gal/g)	4.15 m (13.61 ft)	1.85 m (6.07 ft)	2.45 m (8.04 ft)	2670 kg (5885 lbs)	\$310,800
Oenoflow XL-14A	14	301	140-210 hl/h (3700-5550)	4.40 m (14.43 ft)	1.85 m (6.07 ft)	2.45 m (8.04 ft)	2750 kg (6060 lbs)	Contact us
Oenoflow XL-16A	16	344	160-240 hl/h (4225-6340)	5.10 m (16.73 ft)	1.85 m (6.07 ft)	2.45 m (8.04 ft)	3150 kg (6945 lbs)	Contact us
Oenoflow XL-18A	18	387	180-270 hl/h (4755-7130 gal/g)	5.35m (17.55 ft)	1.85 m (6.07 ft)	2.45 m (8.04 ft)	3250 kg (7165 lbs)	\$400,000

<sup>1</sup> The flow rates for the various Oenoflow XL models are averages for the complete filtration cycle, and dependent on the wine characteristics and pre-treatment.