

Maximum Control of Beverage Quality Portable Dissolved O₂ Analyzer

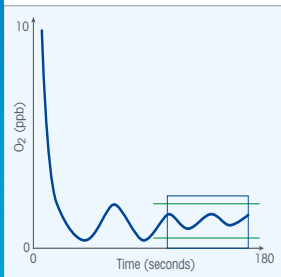

Quick, convenient calibration

The portable InTap DO meter saves time in routine inspections of in-line DO systems. It also eliminates the risk of incorrect calibration of METTLER TOLEDO in-line DO systems.



Fast and accurate low ppb measurement

High beverage quality and avoidance of out-of-spec product are assured with InTap. It uses the same measurement technology as the METTLER TOLEDO low ppb optical DO sensor InPro 6970i, and measures accurately down to 2 ppb.



Data safety throughout production

InTap prevents human error from incorrectly reading handwritten values. Data is accurately recorded and managed by the analyzer for any application, and is made available on its USB drive for further documentation.

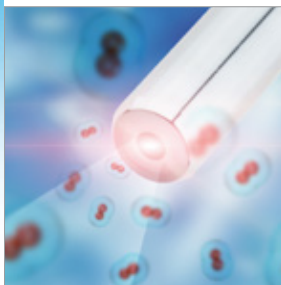

Proven optical technology

Matches the high standards of optical dissolved oxygen sensors, now accepted as standard in brewery applications.



ISM[®]



Reliable, Robust Oxygen Analysis Throughout Production

The InTap, with an internal optical DO sensor, samples and measures dissolved oxygen values at-line and off-line for optimum control of alcoholic beverages and soft drinks – at any point in your production process.

More than that, InTap features Bluetooth communication technology that allows calibration information to be written safely and quickly from the InTap directly to in-line optical DO sensors that are equipped with a T100 Bluetooth tool. The risk of manual copying errors is therefore eliminated.

Measurement point tracking in InTap means operators can easily tie measurement data to different places in production, and maintain records point-by-point for traceability and documentation purposes.

► www.mt.com/InTap

METTLER TOLEDO

Key technical data for the InTap oDO Analyzer

Measurement parameter	Dissolved oxygen saturation
Measuring range	0 to 2000 ppb
Accuracy* (sensor)	≤±(1 % + 2 ppb)
Response time t_{98} at 25 °C (77 °F) (air to N ₂)	< 20 s
Power supply	External: 12 VDC, 2.5 A
Battery lifetime	Up to 24 h
Data storage USB 2.0	3 GB
Operating temperature	-5 to +45 °C (+23 to +113 °F) with media
Operating/design pressure	0 to 6 bar (0 to 87 psi)/10 bar (145 psi)
Protection rating	IP 67
Hose connection	Metric: Swagelock 6 mm or Imperial: ¼" NPT
Weight	3.5 kg (7.7 lbs)
Dimensions (H×W×D)	280 mm × 170 mm × 150 mm (11.0" × 6.7" × 5.9")

* Measurement specification based on sensor specification

Ordering information InTap and accessories

Designation	Order Number
InTap portable oDO analyzer with metric connectors 6 mm	30 425 550
InTap portable oDO analyzer with imperial inch/US connectors: ¼" NPT	30 457 912
T100 M12 Bluetooth sensor interface	30 432 819

► www.mt.com/InTap

Complete trouble-free calibration solution tailored to your needs

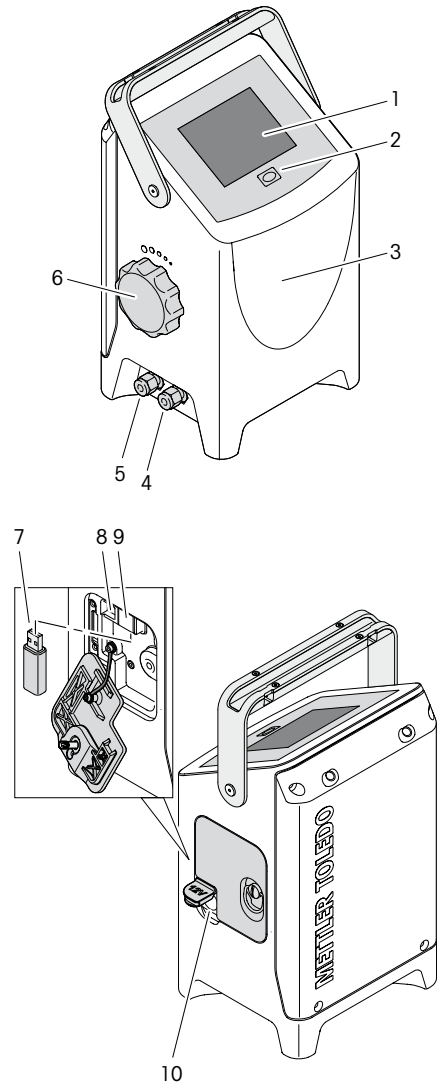
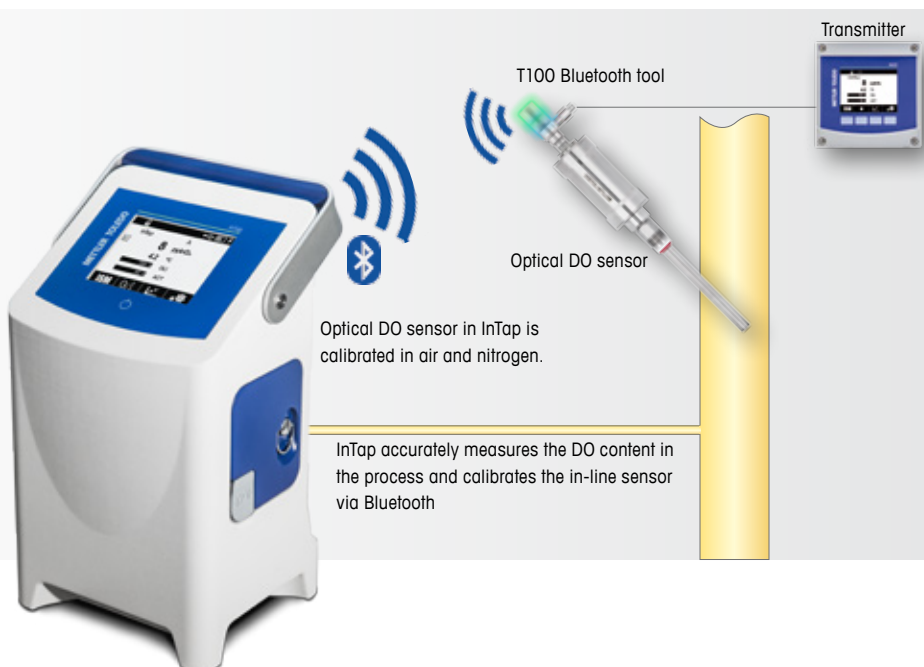

- 1 Monochrome 4" touch display
- 2 On/Off button
- 3 Housing with measurement cell, O₂ InTap sensor, valve, battery, HW board
- 4 Connection for hose "Medium in"
- 5 Connection for hose "Medium out"
- 6 Rotary knob for adjusting medium flow rate
- 7 USB stick for data logging
- 8 USB type B connection for software updates
- 9 USB type A connection
- 10 Connection for AC/DC

METTLER TOLEDO Group

Process Analytics
Local contact: www.mt.com/pro-MOs

Subject to technical changes
© 01/2019 METTLER TOLEDO. All rights reserved.
MarCom Urdorf, CH. PA2004en A.

www.mt.com/pro

For more information

ISM, InTap and InPro are trademarks of the METTLER TOLEDO Group. All other trademarks are property of their respective owners. Subject to technical changes.