

ICC NW's standard, stainless steel wine fermenters are designed to ensure you are in control of the fermentation process. Strategically placed, dimpled heating | cooling jackets allow precise temperature adjustments. All of our standard wine fermenters are made in the USA and predesigned, thus allowing for shorter lead time and faster delivery to your winery.

We also custom-make wine fermenters in all shapes and sizes to fit your individual needs. Please contact us at info@icc-nw.net

Punchable | Convertible Fermenter



- Multi use for fermentation, storage, blending, bottling
- Super-sized removable top manway, air-tight gasket, greater access to cap
- Dimpled cooling | heating jackets
- Gusseted 12" temperature well, sample port
- Sump style drain
- Drain screen
- Sloping bottom
- Racking door
- Pomace door
- Anchor pads for concrete pedestal
- Options: Stainless legs with adjustable foot pads

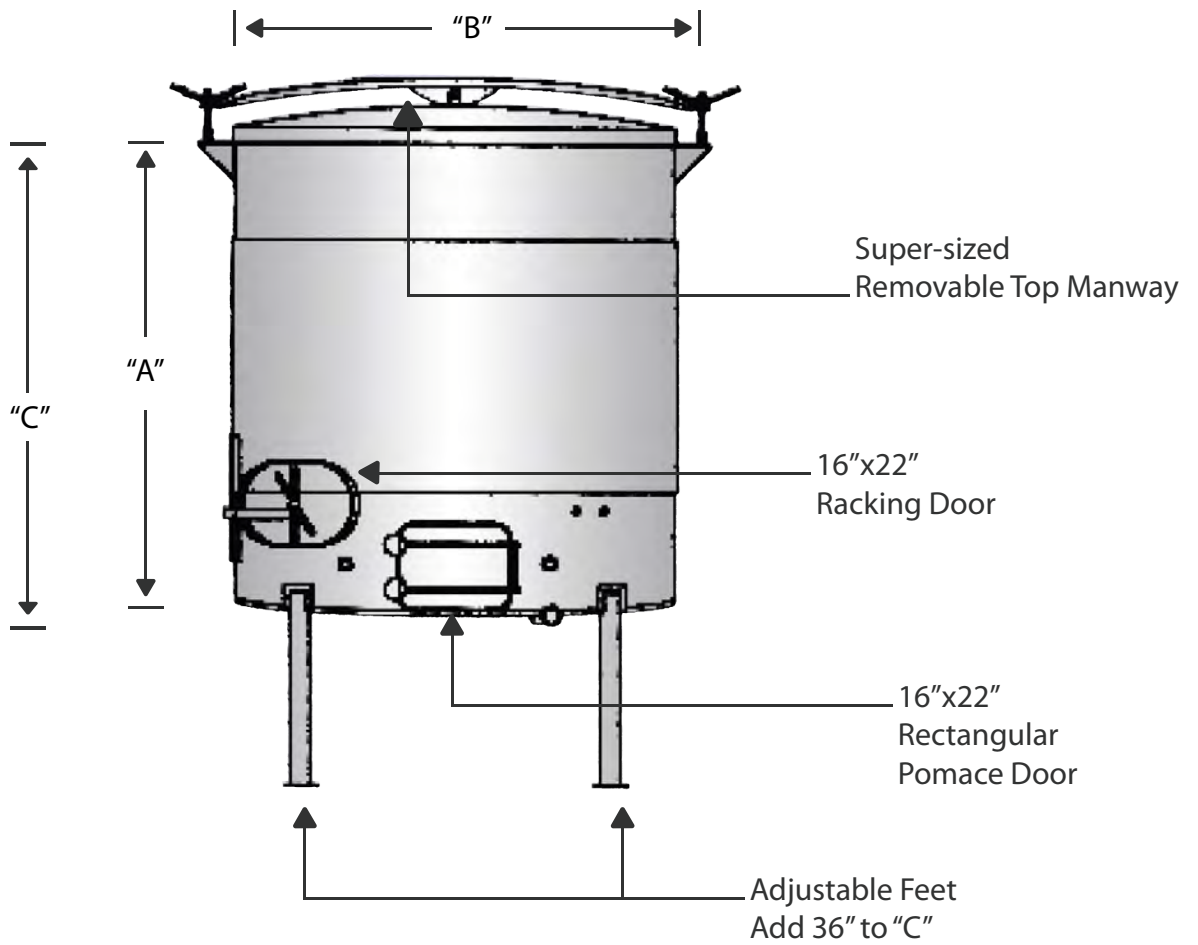

ICC NW's standard, stainless steel wine fermenters are designed to ensure you are in control of the fermentation process. Strategically placed, dimpled heating | cooling jackets allow precise temperature adjustments. All of our standard wine fermenters are made in the USA and predesigned, thus allowing for shorter lead time and faster delivery to your winery.

We also custom-make wine fermenters in all shapes and sizes to fit your individual needs. Please contact us at info@icc-nw.net



Red Wine Open Top Fermenter

- Unlimited access to cap
- Dimpled cooling | heating jackets
- Gusseted 12" temperature well, sample port
- Sump style drain
- Drain Screen
- Sloping bottom
- Pomace door
- Racking Door
- Anchor pads for concrete pedestal
- Options: Stainless legs with adjustable foot pads

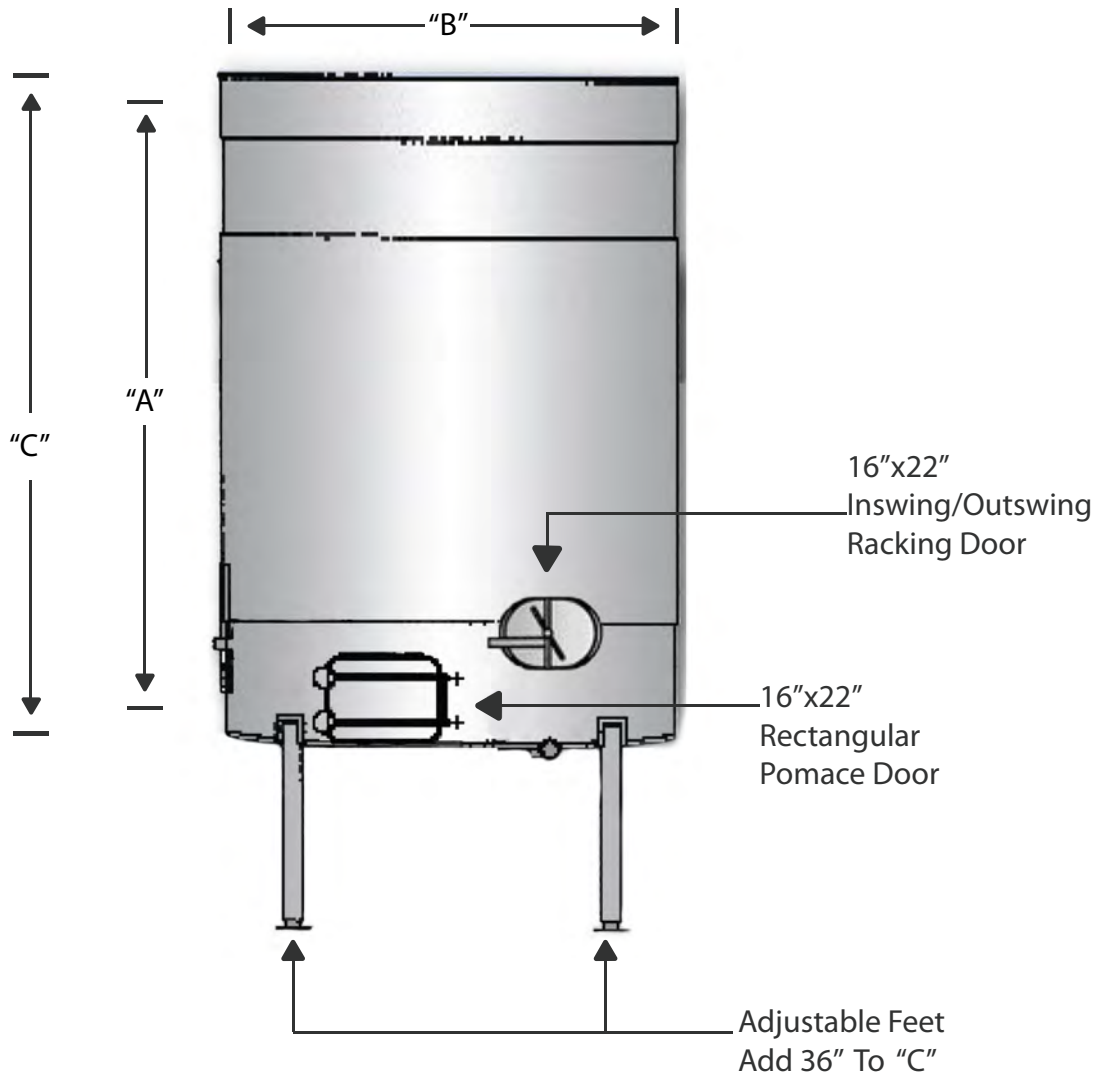

ICC NW's standard, stainless steel wine fermenters are designed to ensure you are in control of the fermentation process. Strategically placed, dimpled heating | cooling jackets allow precise temperature adjustments. All of our standard wine fermenters are made in the USA and predesigned, thus allowing for shorter lead time and faster delivery to your winery.

We also custom-make wine fermenters in all shapes and sizes to fit your individual needs. Please contact us at info@icc-nw.net

Variable Capacity Fermenter



- These tanks allow for varying amounts of product with full access to cap
- Multi use for fermentation, storage, blending, bottling
- Dimpled cooling | heating jackets
- Gusseted 12" temperature well, sample port
- Sump style drain
- Drain screen
- Sloping bottom
- Racking door
- Pomace door
- Anchor pads for concrete pedestal
- Options: Winch assembly, stainless legs with adjustable foot pads

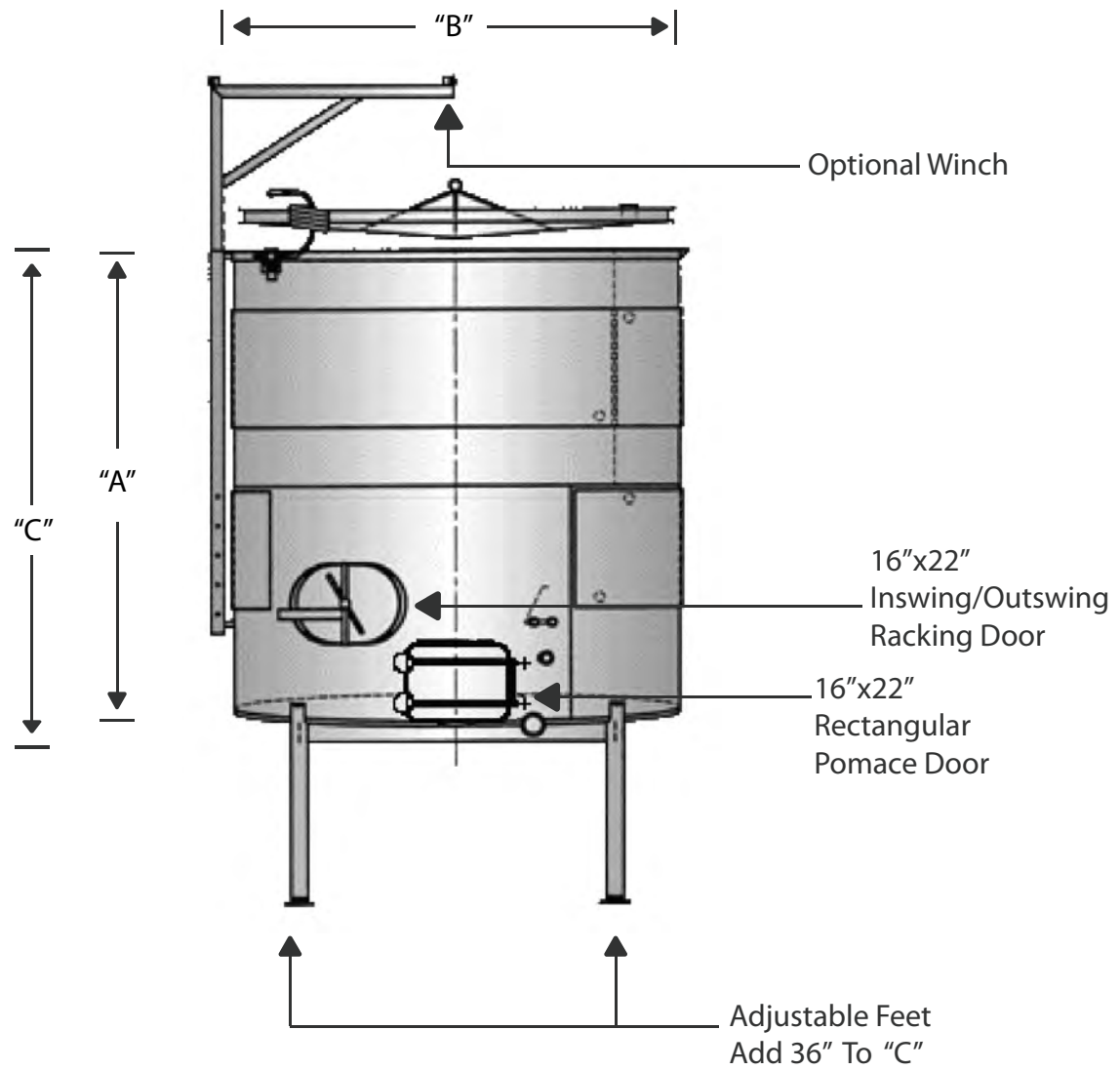

ICC NW's standard, stainless steel wine fermenters are designed to ensure you are in control of the fermentation process. Strategically placed, dimpled heating | cooling jackets allow precise temperature adjustments. All of our standard wine fermenters are made in the USA and predesigned, thus allowing for shorter lead time and faster delivery to your winery.

We also custom-make wine fermenters in all shapes and sizes to fit your individual needs. Please contact us at info@icc-nw.net



White Wine Fermenter

- Multi use for fermentation, storage, blending, bottling
- Dimpled cooling | heating jackets
- Gusseted 12" temperature well, sample port
- Truncated top for easy access
- Sump style drain
- Sloping bottom
- Shrouded inswing | outswing door
- Anchor pads for concrete pedestal
- Options: Stainless legs with adjustable foot pads

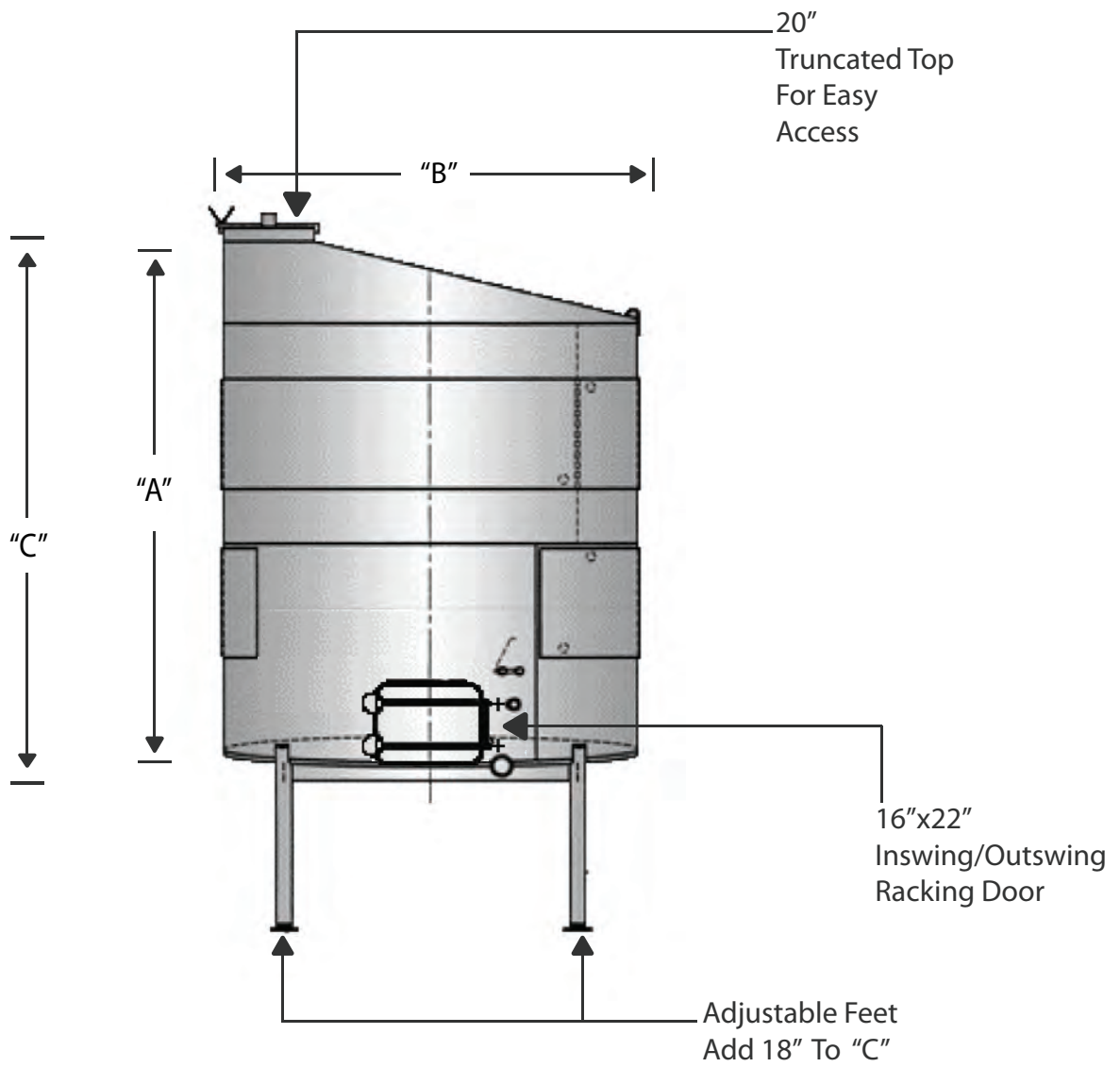

ICC NW's standard, stainless steel wine fermenters are designed to ensure you are in control of the fermentation process. Strategically placed, dimpled heating | cooling jackets allow precise temperature adjustments. All of our standard wine fermenters are made in the USA and predesigned, thus allowing for shorter lead time and faster delivery to your winery.

We also custom-make wine fermenters in all shapes and sizes to fit your individual needs. Please contact us at info@icc-nw.net



White Wine Open Top Fermenter

- Unlimited access to cap
- Dimpled cooling | heating jackets
- Gusseted 12" temperature well, sample port
- Sump style drain
- Pomace door
- Anchor pads for concrete pedestal
- Options: Stainless legs with adjustable foot pads

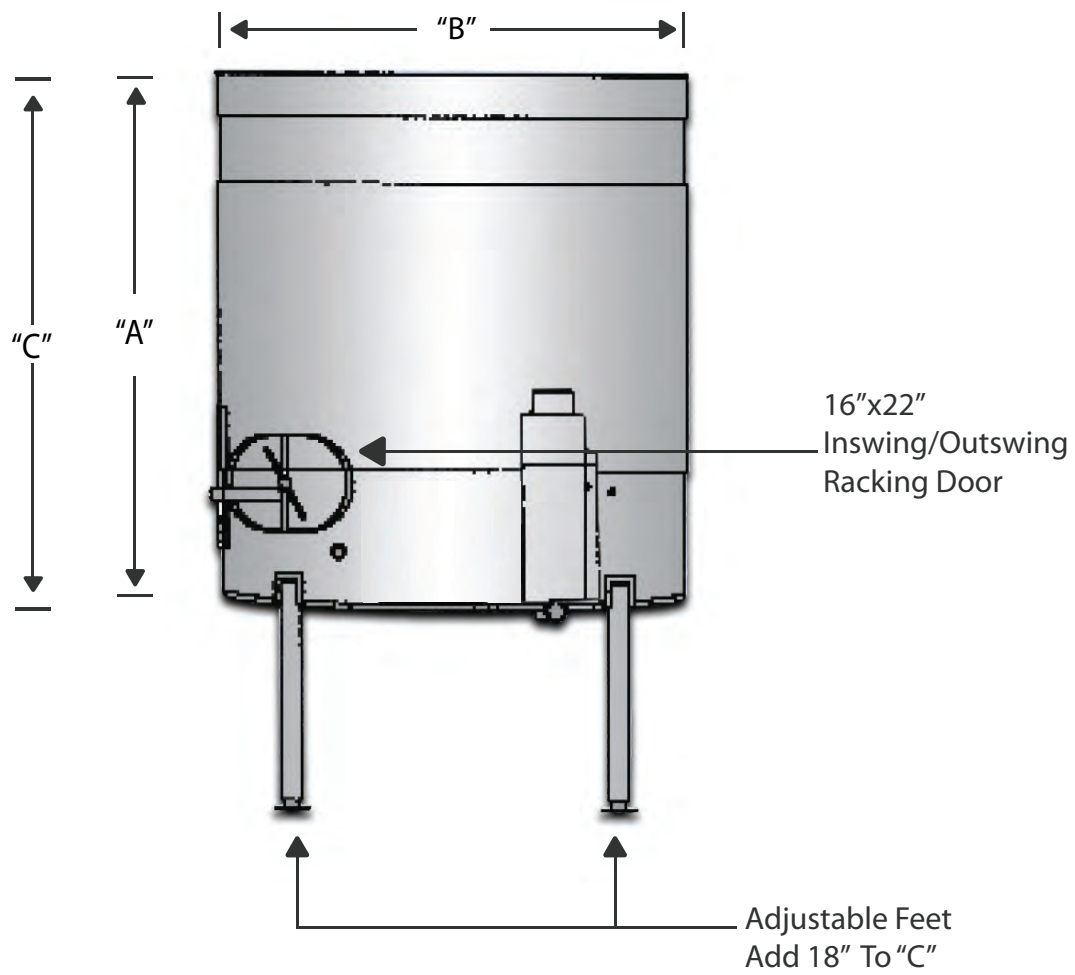

ICC NW's standard, stainless steel wine fermenters are designed to ensure you are in control of the fermentation process. Strategically placed, dimpled heating | cooling jackets allow precise temperature adjustments. All of our standard wine fermenters are made in the USA and predesigned, thus allowing for shorter lead time and faster delivery to your winery.

We also custom-make wine fermenters in all shapes and sizes to fit your individual needs. Please contact us at info@icc-nw.net

Red Wine Fermenter



- Multi use for fermentation, storage, blending, bottling
- Dimpled cooling | heating jackets
- Gusseted 12" temperature well, sample port
- Truncated top for easy access
- Sump style drain
- Drain Screen
- Sloping bottom
- Racking door
- Pomace door
- Anchor pads for concrete pedestal
- Options: Stainless legs with adjustable foot pads

