



Compact case packer

Top loading compact case packer for glass or plastic bottles.
Product infeed conveyor with a smooth flow system.

Synchronization of servo motion and spacing conveyor guarantee good positioning of bottles.
Pick and place system with a smart patented adjustable gripping head.

Flexible case packer for 4 cases of 6 bottles or 2 cases of 12 bottles. Bottles diameter and height quick change over, no bottle guiding needed.

We work to improve ergonomics by designing compact machines with easy and secured access.

Application : beverage and liquid

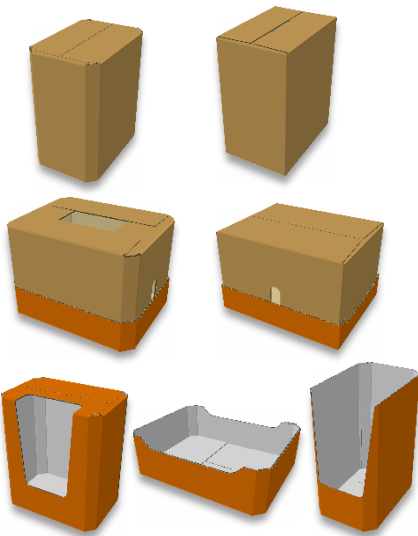

Some case examples

[#PackagingStrategists](#)



Process

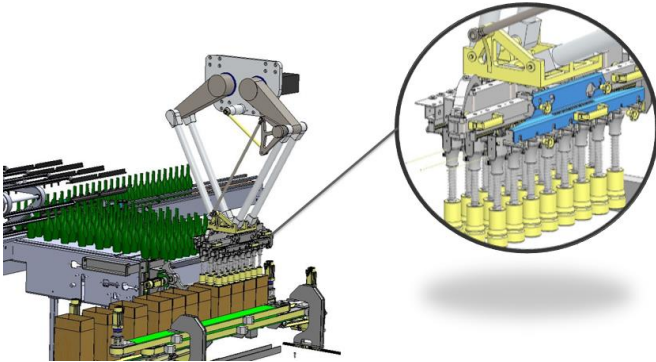

Layout

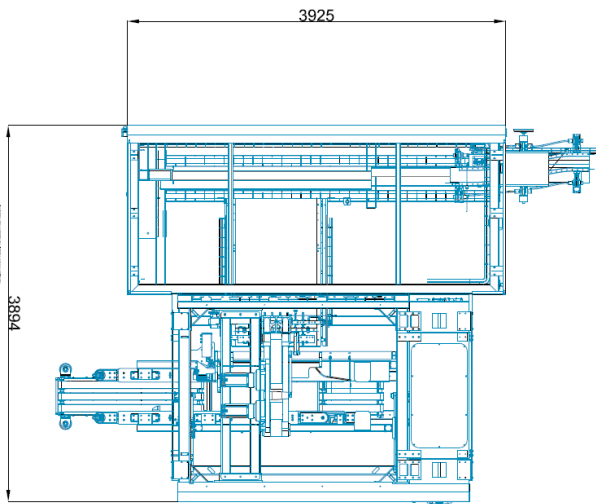

Technical features

Machines	Bottle diametER	Output maxi	Machine dim (mm)
EVA 15	Mini:61 mm Maxi:100	15 000 bottles per hour	5634x3894x3020
EVA 7		7 000 bottles per hour	
EVA 3		3 000 bottles per hour	

- Format change : approx. 2 min

Main Features

- Servo driven
- Robotic product handling
- Adjustable head
- Flexible as modular machine or integrated in a combiline

Benefits

- Smooth infeed and no touch, no noise
- Flying trajectory allows no hopper
- Easy access
- Quick change over
- Low maintenance costs
- Compact lay out
- Product divider : Up stream or downstream

Packaging flexibility

- Transport packaging and / or SRP/RRP
- 4 or 8 corners cases
- Standard, short flaps
- Window
- Half case

DS SMITH PACKAGING SYSTEMS

12 rue Gay-Lussac

ZI Dijon-Chenove

21302 Chenove

Tel: +33 (0)3 80 54 00 20

www.dssmith.com/packagingmachinery

#PackagingStrategists