



VORTEX

— TAP —

WHO ARE WE AND WHAT ARE WE DOING HERE?

MISSION: Vortex Taps sees the massive importance of BIB packaging in the wine industry and has been focused on developing innovation to drive the perception, expectation of quality, and excitement around box wine to new heights



Today, we'll discuss:

- A little bit of background – the boxed wine industry then and now
- Innovation/Marketing in Bag in Box Market
- Social innovation and marketing
- Simple solutions, big impact
- Giving consumers more of what they love

WHO ARE WE?

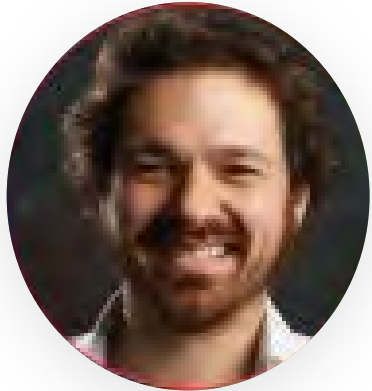

NATHANIEL ROBERTS

Founder of Vortex Taps. Led the Design of the Vortex Tap Technology at Amnity Designs as a product developer.



YVES BRECHBILL

Industrial Designer Former automotive designer. Created structural and cosmetic plastic parts for Volvo, Jaguar, VW/Audi, Ford. B/S in Industrial Products Design.



FONGLOON (PETER) PAN

Senior Aerodynamics and CFD Engineer for Honda R&D Americas. Holds an MS in Aeronautics and Astronautics from Purdue.



ELLE ALLEN

Consultant Technical and communications consultant for Vortex, Elle comes from over a decade working in aerospace. She holds a BS/MS in mechanical engineering and has designed and launched over 73 parts on Falcon 9 rockets.



WHY BOX WINE?

- ✓ It's a provably rapidly growing market
- ✓ Success started with logistics and shipping simplicity and has taken off from there
- ✓ Bigger and more sophisticated brands are picking up on the trend
- ✓ Wine lovers in younger generations showing a huge amount of interest
- ✓ Massive environmental impact furthering the hype – 80% reduction of carbon emission switching from bottle to box
- ✓ Still a market for bottles for aging fine wines – but these only take up around 10% of the total market. 90% of year-over-year produced wine is meant to be consumed within a year of its production
- ✓ Within the next year, the US market will grow to be the largest e-commerce source of direct to consumer wine
- ✓ Box wine options reduce the overwhelm of consumers facing rows of unknown bottles

WE'RE NOT THE ONLY ONES INTERESTED...

CLUB OENOLOGIQUE
NEWS - 15 JULY 2020

Premium bag-in-box wine – has its time finally come?

With environmental issues now centre stage, and online ordering rampant, what was previously seen as déclassé is being taken increasingly seriously by wine lovers

WORDS BY ADAM LECHMERE

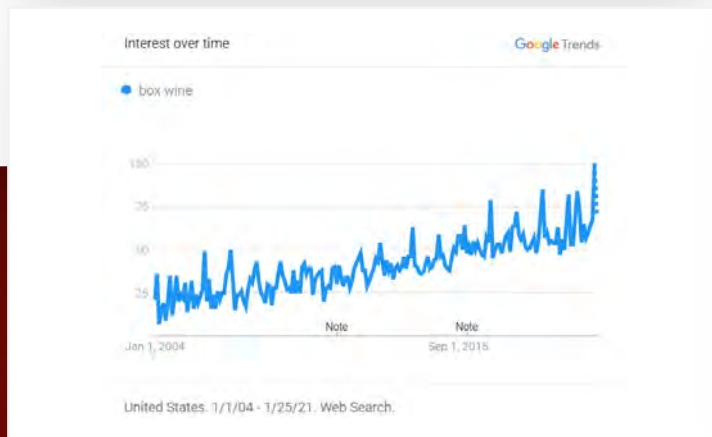

WINE BUSINESS.com
HOME PAGE FOR THE WINE INDUSTRY

Boxes Popular as Consumers Remain Stuck at Home

The sales numbers speak for themselves. While 3L and 4L bottles have seen sales drop significantly in recent years, Black Box and Bota Box have been among the bestselling brands in the same period. The growth continued during the pandemic, as boxes logged 31% growth in the 13 weeks ended June 13. While sales

wine intelligence

PANDEMIC UNLOCKING GROWING OPPORTUNITY FOR ALTERNATIVE WINE FORMATS IN US AND CANADA

Wine consumers in the US and Canada are reappraising their relationship with different wine formats – cans, box wine and other non-glass formats – now seeing them in a new and more positive light

IWSR
drinks market analysis

Changing millennial preferences drive packaging innovation and on-site experiences at US wineries

Growth in still wine has been slowing down over the past few years, prompting US wineries to drive packaging and brand innovation, as well as on-premise experiences, to increase their appeal to younger consumers.

WHAT'S THE HOLD-UP?

Past Perceptions

- ✗ Poor quality options
- ✗ Poor quality taste
- ✗ Box wine = cheap wine
- ✗ Low aesthetic appeal
- ✗ Older wine-drinkers have outdated perception

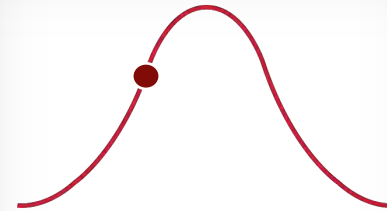

A Hump Exists

Direction and State of BIB Industry

- ✓ Reliable and trusted options
- ✓ Good quality wine
- ✓ Better value
- ✓ Trendy aesthetic appeal
- ✓ Environmentally friendly
- ✓ Strong ecommerce opportunity
- ✓ Younger buyer interest is high



“Businesses that may have leaned a little heavily on the older demographics and not changed messaging to be meaningful to younger consumers have not benefited as strongly in 2020”

Wine Producer, US

HOW DO WE CLOSE THE GAP?

- Leverage what's already taking off
- Provide a higher quality taste
- Provide a higher quality experience
- Give wine-drinkers a sense of reliability, security, indulgence around their choices
- Create new hype - social talking points that are shareable, exciting and functional
- Add to positive perception in a social environment
- Bring sophistication to and curiosity to the package
- ➔ Craft an even better brand image of boxed wine



AND THAT'S
WHERE WE
COME IN

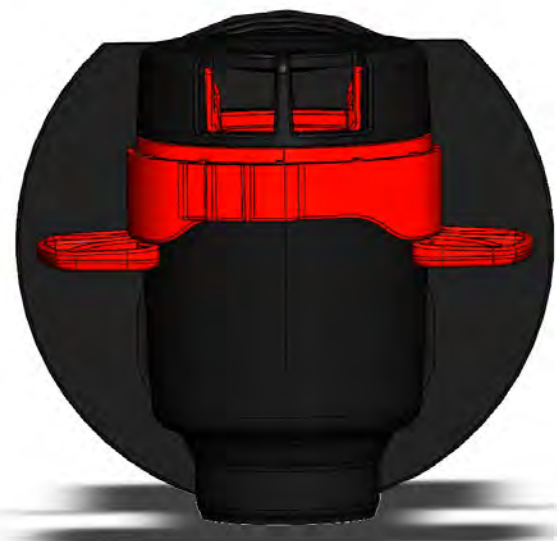

AERATION AT YOUR FINGERTIPS

- Reviewers Agree, Aerator = better tasting wine
- Strong existing consumer base
- \$100+ million in US sales from 2020*
- Simple way to produce a high-quality feel
- Functionality of Alternative packaging generates an excitement to share and experience/ taste the difference, which means they will talk.
- Aerators carry a positive perception that entice even the biggest box wine fans.
- BIB aeration allows for the best of both worlds: aerated wine from oxygen-sealed packaging

What Does a Wine Aerator Do? Elevates a Wine's Flavor Profile

Many researchers say that up to 80% of taste is smell. In much the same way a wine's bouquet is enhanced by aeration, a wine's flavor profile is likewise elevated by the moderation of ethanol and sulfites.



Amazon Home Shop by Room Discover

1-24 of over 1,000 results for "wine aerator"



Vinaera - World's First Electronic Wine & Spirit Aerator / Dispenser

★★★★☆ - 108

\$230⁰⁰

FREE Shipping



Vintorio Wine Aerator Pourer - Premium Aerating Pourer and Decanter Spout (Black)

★★★★☆ - 9,222

\$16⁹⁹

prime | FREE Same-Day FREE delivery Today, Jan 25 on qualifying orders over \$35



Vinturi Red Wine Aerator Includes Base Enhanced Flavors with Smoother Finish, Black

★★★★☆ - 4,879

\$19⁹⁹ ~~\$28.95~~

FREE Shipping



Rabbit Wine Aerator and Pourer, 1.1 x 1.1 x 5.2 inches, Clear/Stainless Steel

★★★★☆ - 1,631

\$13⁰² ~~\$14.59~~

prime | FREE Same-Day FREE delivery Today, Jan 25 on qualifying orders over \$35

More Buying Choices \$11.48 (12 used & new offers)



VINVOLI Wine Aerator - New 2021 Luxury Wine Air Aerator - Red Wine Decanter Aerator - Wine Aerator Wine Pourer - Wine Filter Sulfite...

★★★★☆ - 759

\$19⁹⁹

prime | FREE One-Day Get it Tomorrow, Jan 26

More Buying Choices \$17.14 (2 used & new offers)

★★★★☆ - 9,222

Ref: <https://www.360researchreports.com/global-wine-aerator-market-15066991>

DEMAND FOR BAG-IN-BOX AERATION TECHNOLOGY IS THERE



BOX-Ae-RATOR | boxaerator: The Box Wine Aerator

~~\$60.00~~ \$50.00 Sale
Tax included. Shipping calculated at checkout.

Quantity

ADD TO CART

Buy with Pay

[More payment options](#)

The BOX-Ae-RATOR is the only wine aerator in the market specifically designed to aerate boxed wine.

★★★★★ Wine for Wine's sake | Verified Reviewer | De Pere, WI

16 days ago

Fun AND Practical

I have been using my BOX-Ae-RATOR for the last several months now, but over the holidays was able to pull it out and show it to my Family and Friends. For fun we did the blind taste challenge, and 100% of the time the wine that went through the BOX-Ae-RATOR was unanimously voted as the better tasting wine. It was not only Fun to do, but the end result was better tasting wine for all of our Guests. Fun AND Practical.....what more could you ask for?

★★★☆☆ Sylvania | Verified Reviewer | Denver

19 days ago

Great idea, not-so-great execution

I was really excited to gift this to my husband for Christmas because we both love having boxed wine in the home when we want to save some money, but was disappointed by the product. It's incredibly messy, spills wine every where, and isn't easy to use. I wish we loved it but I just wanted to warn potential buyers about this...

Reponse from Amy
Hi Sylvania! We're sorry you were disappointed in this product. Please know, we have a forever return policy if you would like to utilize that! <https://support.uncommongoods.com/hc/en-us/articles/225245807-Return-instructions>

★★★★★ KG007 | Verified Reviewer | Chicago, IL

1 month ago

A must have for any boxed wine lover!

Initially purchased this product to enhance our boxed wine drinking experience. The box ae rator did not disappoint us and it truly improved the taste and quality of our favorite boxed wines. We love and use this product so much, we are now purchasing another one as a wedding shower gift for a happy boxed wine drinking couple!! Great price for such a valuable and high quality item. Cheers!!!

Maker's Market Is Creating Solutions

**Instead Give
Them Simple,
Easy To Use
Solutions Right
At Their
Fingertips...**



Wine Producers Need To Keep It Simple

As demographic shifts change the way wine producers respond to consumer preferences, the US wine market has an opportunity to break norms even further. Wineries that want to appeal to younger consumers need to simplify the way these consumers approach the category. This is a market segment that has typically viewed selecting a wine as a complicated process in terms of pronunciation, understanding, package size, how to open, and even the correct way to sip and describe what they are drinking. Younger consumers increasingly want something that is, quite simply, easy to drink.

TECHNOLOGY SHOWCASE - DESIGN

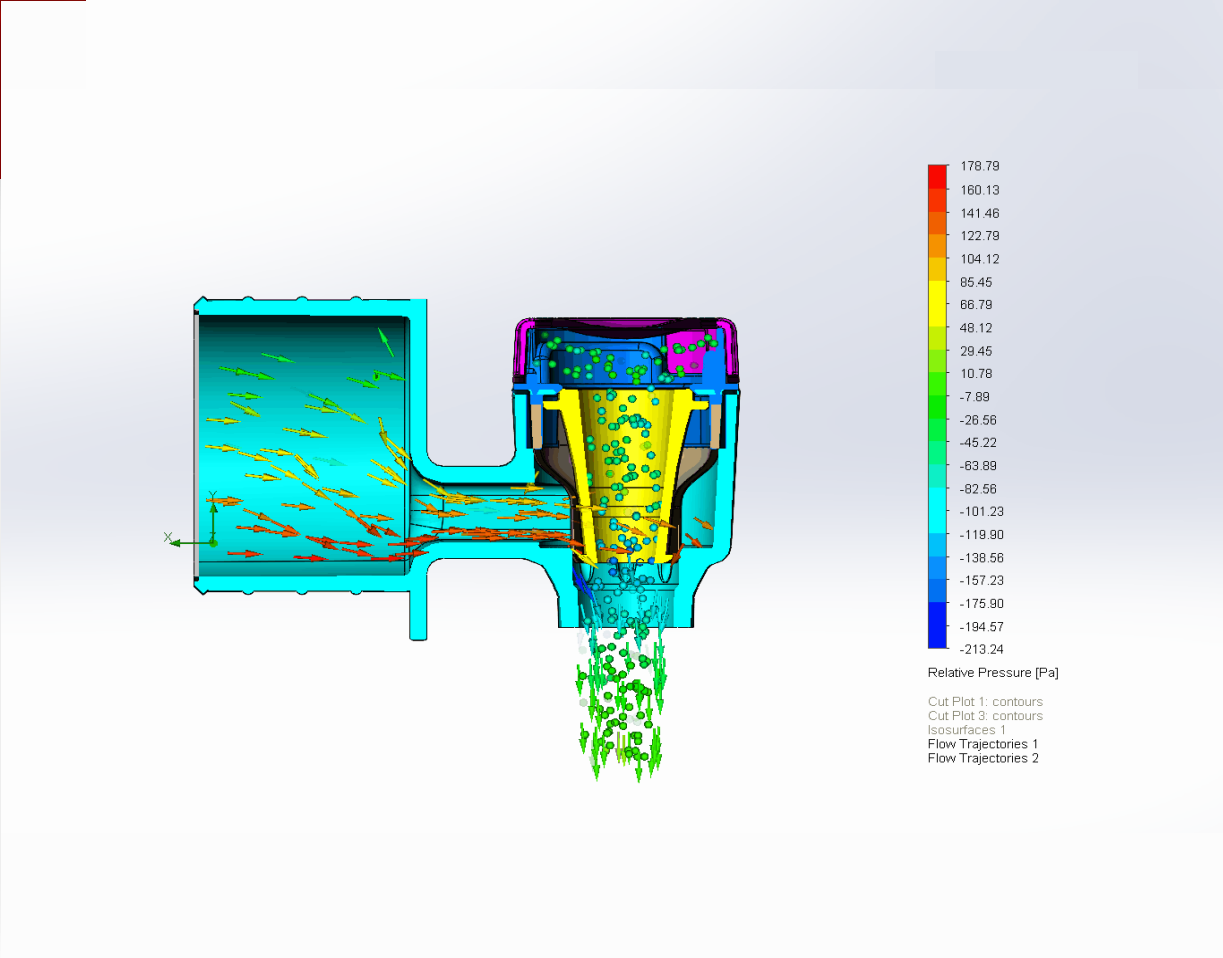

TECHNOLOGY SHOWCASE – ANALYSIS AND TEST

- Dissolved oxygen tests show that it works as well as aerators on the market today.
- Flow tests show when, where, speed of aeration and flow

	Top aerator brand	Vortex taps
O2 by volume		

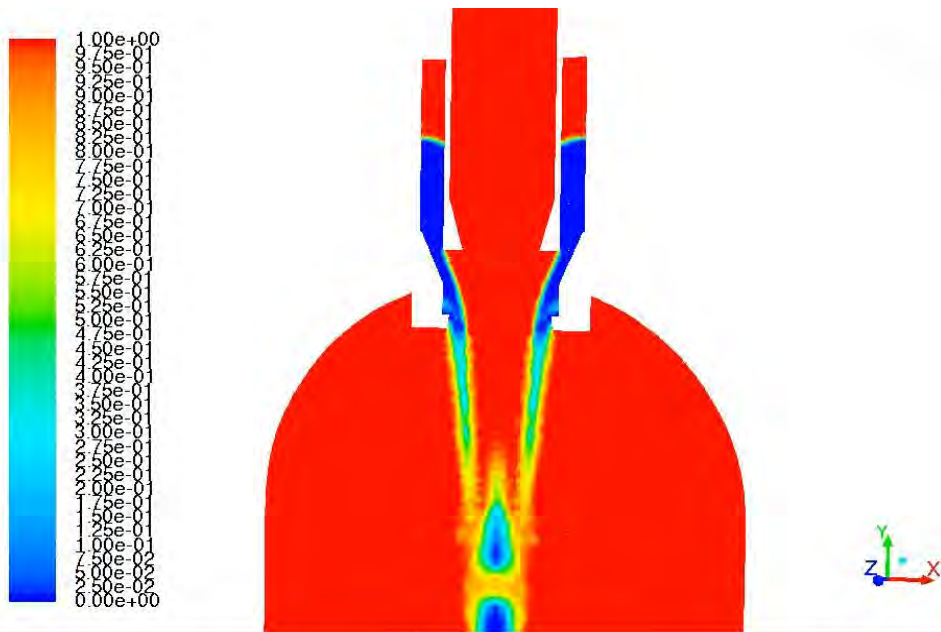

Contours of Volume fraction (air) (Time=7.1037e-01) May 25, 20
ANSYS Fluent 15.0 (3d, dp, pbns, vof, ske, transie)

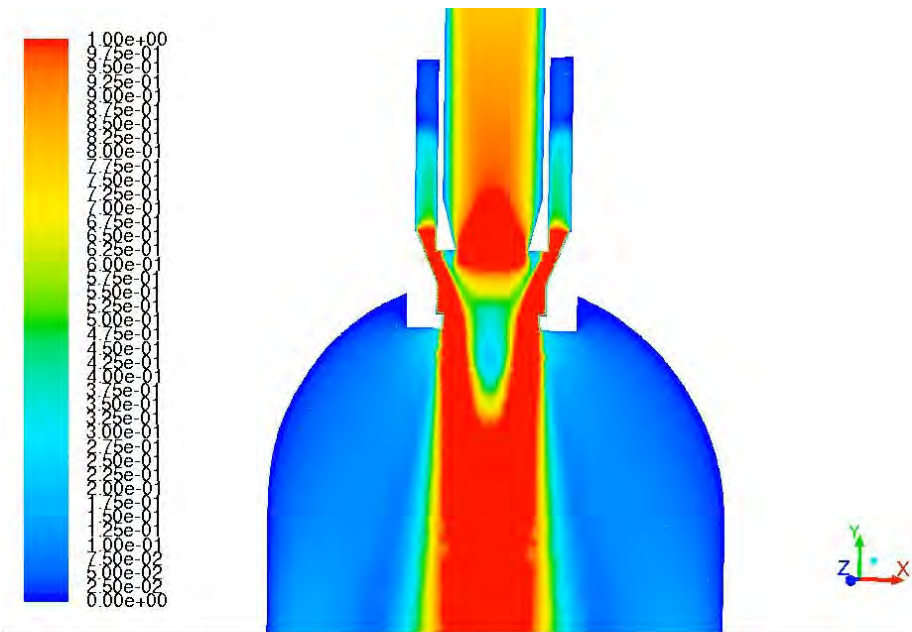

Contours of Velocity Magnitude (mixture) (m/s) (Time=7.0726e-01) May 25, 20
ANSYS Fluent 15.0 (3d, dp, pbns, vof, ske, transie)

TECHNOLOGY SHOWCASE

- Patent Granted in the US
- Filed and Pending in EPO, AUS, China, South Africa

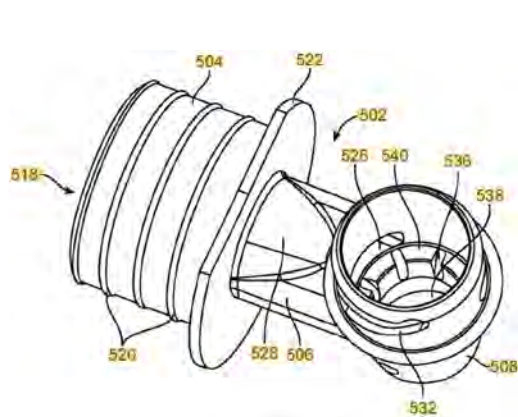

FIG. 11

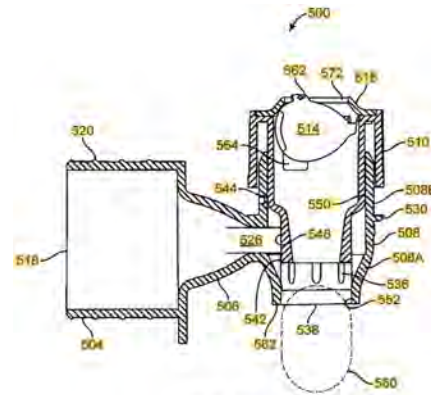
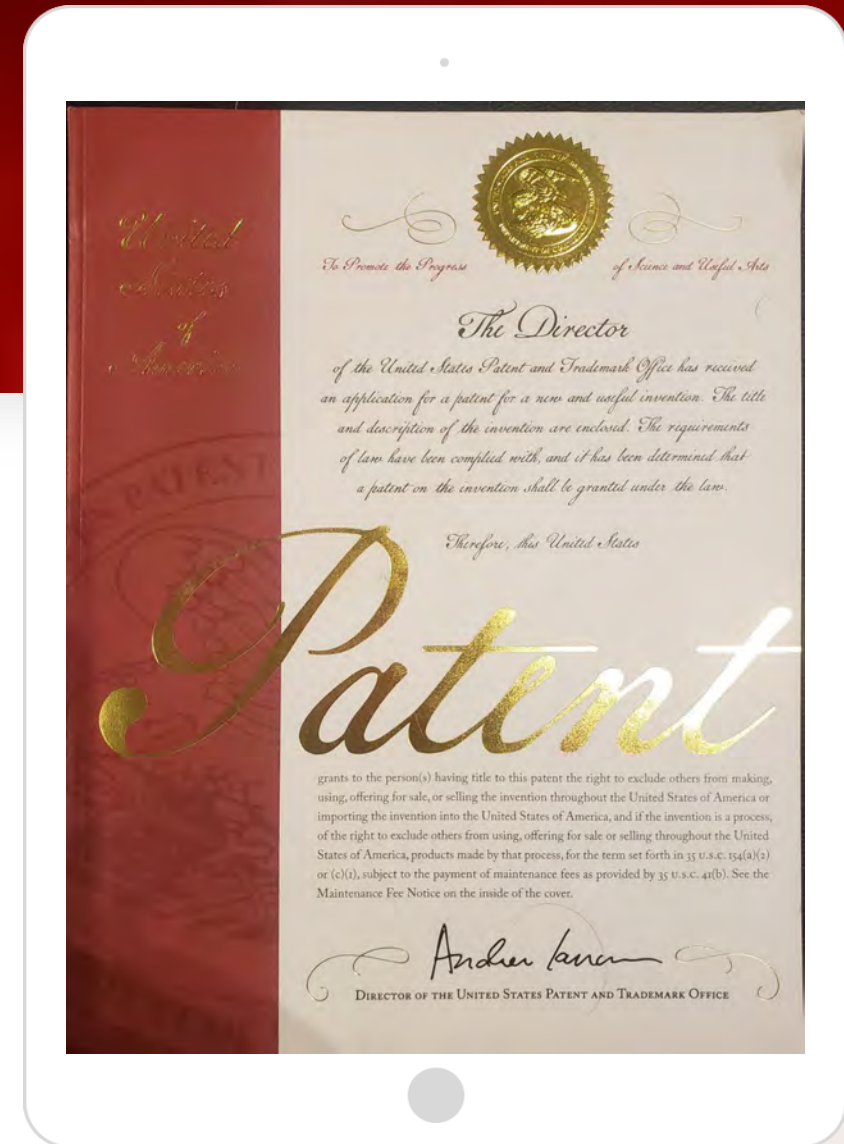

FIG. 23



BUT WHAT WOULD YOUR MOM SAY?

- “I like this one better!”
- “When can I get one?”
- “It’s the same product, but this one is smoother”
- “Why haven’t I heard about this?”
- “I can’t wait to do box wine challenges”
- “Why does it taste so much better?”

01 | From a **Sommelier** to a college valley girl, people taste the difference.

02 | 7 out of 10 prefer the aerated wine and 10 out of 10 taste a difference.





HOW CAN YOU GET INVOLVED AND WHAT ARE WE OFFERING?

Product Design Partnership

- We take your existing design and integrate an aerator
- Design engineering customized to your solutions
- Consulting to different levels of involvement

Technology Integration/Licensing

- You take our turnkey design solution and license it
- IP licensing options available as well



VORTEX
—TAP—

ELEVATE YOUR
BOX WINE
EXPERIENCE
WITH
AERATION

REFERENCES

https://www.depts.ttu.edu/hs/texaswine/docs/Final_Alternative_Packaging.pdf

<https://cluboenologique.com/story/premium-bag-in-box-wine-has-its-time-finally-come/>

<https://www.wineintelligence.com/pandemic-unlocking-growing-opportunity-for-alternative-wine-formats-in-us-and-canada/>

<https://www.winebusiness.com/news/?go=getArticle&dataId=234911>

<https://www.wineintelligence.com/wine-packaging-and-the-rise-of-e-commerce/>

<https://www.theiwsr.com/changing-millennial-preferences-drive-packaging-innovation-and-on-site-experiences-at-us-wineries/>

<https://www.360researchreports.com/global-wine-aerator-market-15066991>