

# **SPIN CLEAN** PLASTIC FILTERS



**World Leader in Irrigation Technology**

“JAIN Spin Clean Filters are easy to install and self flushing helping to maximize our efficiency on job sites. This also frees up valuable time to spend with our clients focusing on added value above ground.”

**Stacey Sturnot**, Gothic Landscapes  
San Diego, CA

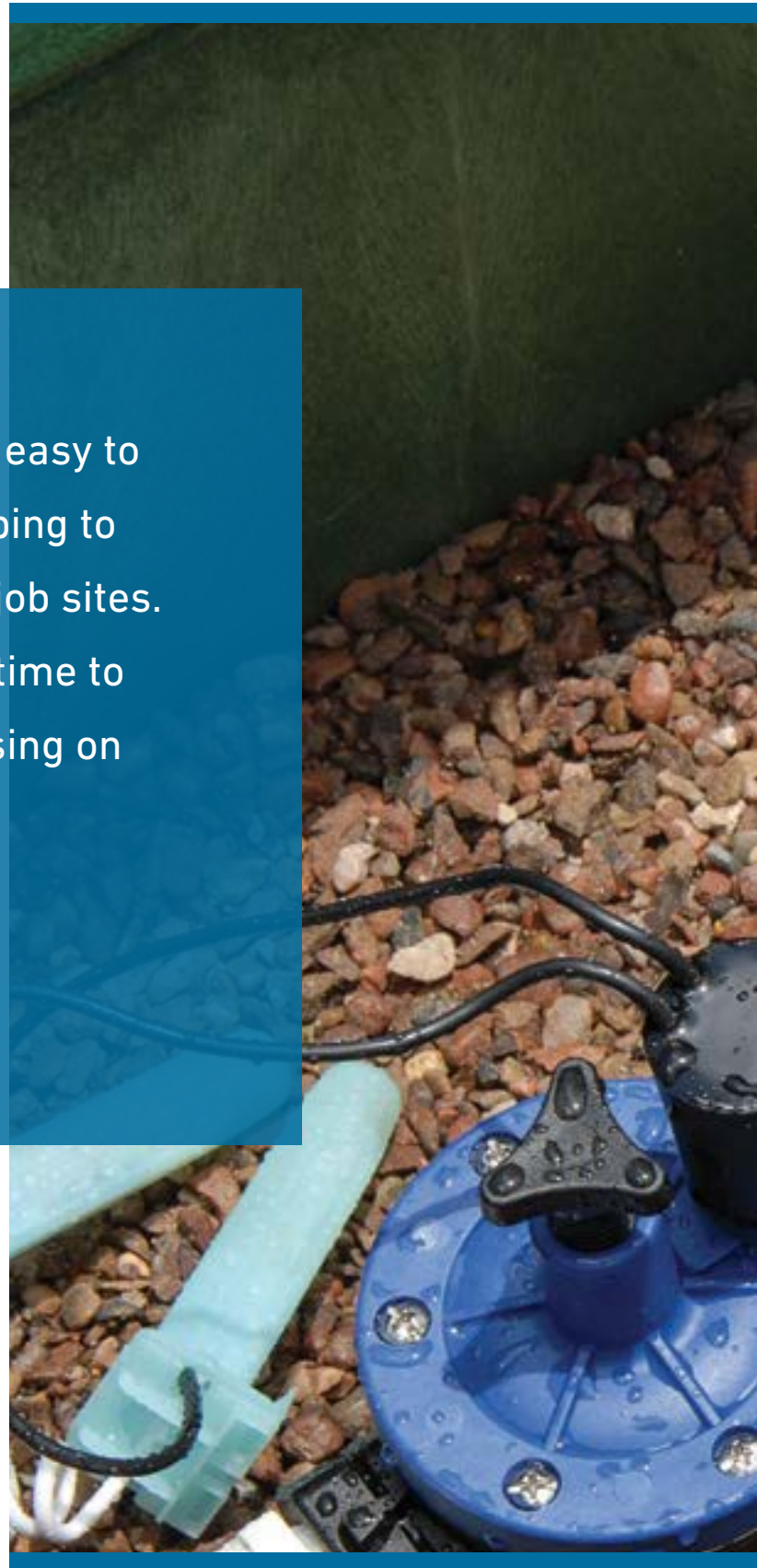



# Plastic Spin Clean 4E Filters

## Product Features

- No moving parts
- Unique Spin Clean action keeps the screen clean during operation
- Engineered plastic construction is light in weight and resistant to corrosion and injected chemicals
- Two piece threaded housing with O-ring seal for easy screen access and maintenance
- Pressure ratings of 80 psi available in ¾" and 1" models, 150 psi rating for ¾" to 2"
- Strong stainless steel screen elements available in 30, 50, 100, 150 (standard) and 200 mesh
- Vinyl screen collars prevent debris from by-passing filter area
- Suitable for both above and below grade in box installation
- Available with ball valve for flushing debris basin
- Only 5-8 psi pressure loss required across filter to ensure best self cleaning action

## Your Natural Choice for Vineyards and Orchards

Plastic Spin Clean Filters are unique screen filters that stay clean during operation. They effectively keep debris moving across the screen element towards the basin, where it is collected and can be drained.

The 4E Plastic Spin Clean Filter is best suited for applications where the contaminants are heavy particles like sand.



# Models and Specifications

Type	Inlet/Outlet Size	Inlet/Outlet Type	Basin Cap or Valve	Basin Outlet Threads	Maximum Flow Rate (gpm)	Maximum Working Pressure (psi)
4E-3/4 A	3/4"	MPT	Cap	3/4 MPT	11	80
4E-3/4 B	3/4"	MPT	Valve	3/4 MPT	11	80
4EH-3/4 A	3/4"	MPT	Cap	3/4 MPT	11	150
4EH-3/4 B	3/4"	MPT	Valve	3/4 MPT	11	150
4E-1 A	1"	MPT	Cap	3/4 MPT	20	80
4E-1 B	1"	MPT	Valve	3/4 MPT	20	80
4EH-1 A	1"	MPT	Cap	3/4 MPT	20	150
4EH-1 B	1"	MPT	Valve	3/4 MPT	20	150
4EH-1 1/2	1 1/2"	MPT	Valve	3/4 MPT	55	150
4EH-2 P	2"	MPT	Valve	3/4 MPT	120	150

## Ordering Information:

### Examples: Type -Screen Mesh

- 4E-3/4B-200 3/4" MPT w/MHT flush & Ball Valve (80psi) w/200 mesh screen
- 4EH-1A-30 1" MPT w/MPT flush & Ball Valve (150 psi) w/30 mesh screen
- 4EH-1½-150 1½" MPT w/MPT flush & Ball Valve (150 psi) w/150 mesh screen

### Options:

All models – Drilled and tapped 1/8" hole for pressure gauge, Shrader Valve or 1/8" mipt fitting at inlet and outlet boss 1" and larger models – BSP Threads

- Please call customer service for availability

### Minimum Clearance

Size	X	Y
4E-3/4 & 1 w/cap	5"	8"
4E-3/4 & 1 w/valve	6"	12"
4EH-1-1/2	4"	15.5"
4E-02	4"	15.5"

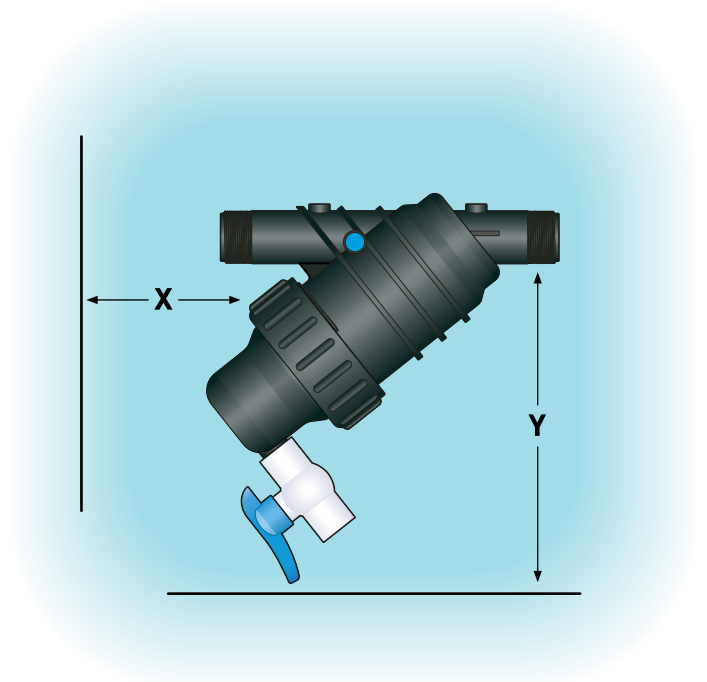

# Specifications

## Size Selection Guide

Specifications		3/4"	1"	1 1/2"	2"
Screen area in square inches (cm <sup>2</sup> )		23.4 / 151.0	23.4 / 151.0	60.8 / 392.3	60.8 / 392.3
Housing material (80 psi pressure rating)		ABS	ABS	N/A	N/A
Housing material (150 psi pressure rating)		Engineering Grade Plastic	Engineering Grade Plastic	Engineering Grade Plastic	Engineering Grade Plastic
30, 50, 100, 150, & 200 mesh stainless steel screens		Yes	Yes	Yes	Yes
Sintered screens		No	No	Yes	Yes
Clearance height in inches (with valve)		12"	13"	15.5"	
Width in inches (thread to thread)		6 1/8"	6 5/8"	12"	12"
Drilled/tapped 1/8" hole for gauge or schrader		Optional	Optional	Optional	Optional
Debris Basin Flush Port Size	Low pressure	3/4" MHT	3/4" MHT	N/A	N/A
	High pressure	3/4" MPT	3/4" MPT	3/4" MPT	3/4" MPT

## Flow Characteristics

Spin plate size	3/4"	3/4"	1	1	1 1/2"	1 1/2"	1 1/2"	2"	2"	2"
Jets	1	2	1	2	2	3	4	2	3	4
Qmax (gpm)	7	11	15	20	25	38	55	75	95	120
Qmin (gpm)	5	7	9	13	18	23	37	50	62	85

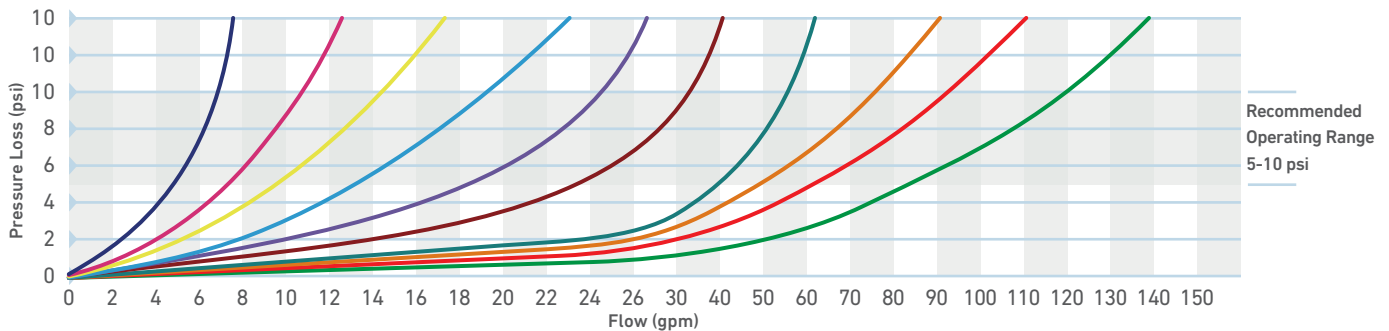

Model #	Part #	Notes/Reference	Range (gpm)
3/4"-SP	12140001	3/4" 2-Hole (standard)	9 with 1 jet to 20 with 2 jets
1-SP	12140002	1" 2-Hole (standard)	5 with 1 jet to 11 with 2 jets
1 1/2-SP	12140013	1 1/2"-4 Hole	37-55
1 1/2-SP-3	12140058	1 1/2"-3 Hole	23-38
1 1/2-SP-2	12140059	1 1/2"-2 Hole	18-25
2-SP	12140029	2"-4 Hole	85-120
2-SP-3	12140061	2"-3 Hole	62-95
2-SP-2	12140060	2"-2 Hole	50-75

### Housing Dimensions

Size	A		B		C	
	in	cm	in	cm	in	cm
3/4"	6.2	15.8	8.5	21.6	3	7.6
1"	6.8	17.3	9.5	24.1	3	7.6
1 1/2"	12	30.5	12	30.5	5.5	14.0
2"	12	30.5	12	30.5	5.5	14.0

### Screen Dimensions

Size	A		B		C		Screen Material	Area of Filtration	
	in	cm	in	cm	in	cm		sq in	sq cm
3/4" and 1"	5.25	13.3	1.78	4.5	1.6	4.1	Stainless Steel	23.4	151.0
1"	6.25	15.9	1.78	4.5	1.6	4.1	Stainless Steel	28.4	183.2
1 1/2" and 2"	7.25	18.4	3.5	8.9	3.2	8.1	Stainless Steel	60.8	392.3

1" Screen



1 1/2" & 2" Screen

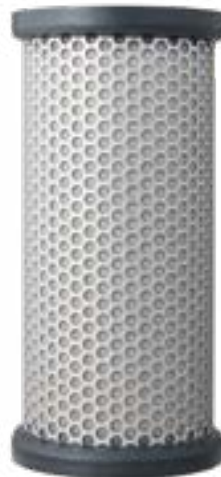

### Filter Screen Mesh/Micron Conversions

Color	Gold	Yellow	Blue	Black	Red
Mesh	30	50	100	150	200
Inch	.023	.012	.006	.004	.003
Micron	590	300	152	100	80

# Flow Range & Characteristics

## Flow range

GPM (m <sup>3</sup> /hr) with Flow Inserts installed in Spin Plate							
Filter Model	Fully Open Spin Plate	1 Flow Insert	2 Flow Inserts	3 Flow Inserts	4 Flow Inserts	5 Flow Inserts	6 Flow Inserts
5E-40	31-40 (7.0-9.1)	31-40 (7.0-9.1)	31-40 (7.0-9.1)	31-40 (7.0-9.1)	31-40 (7.0-9.1)	31-40 (7.0-9.1)	31-40 (7.0-9.1)

## Flow Characteristics

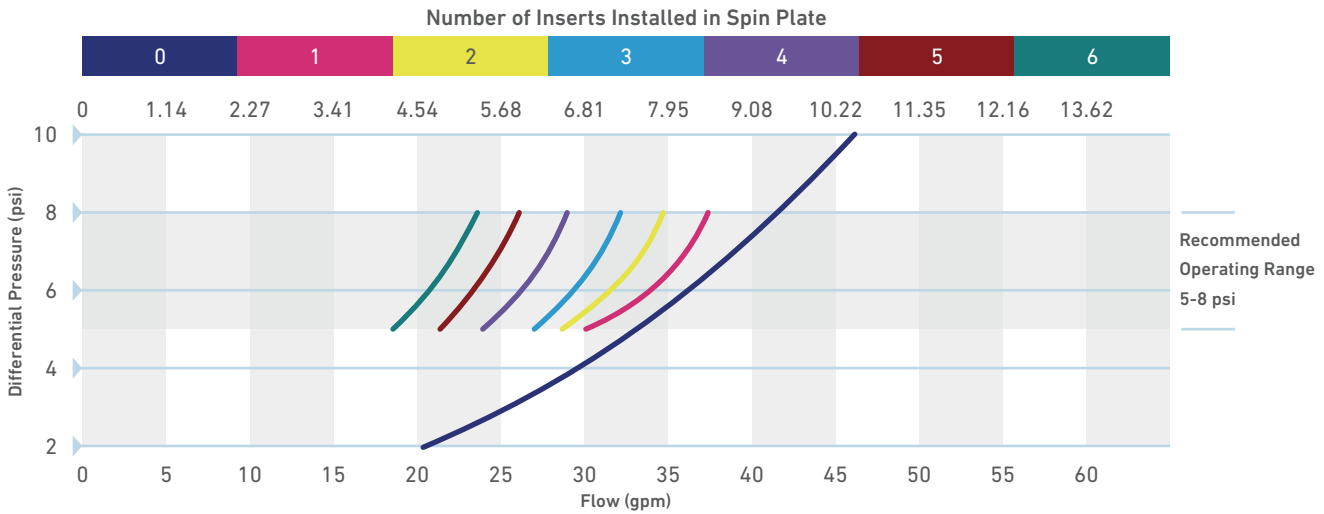

## Operation

The JAIN Spin Clean filter is superior to other standard screen filters because it combines the action of a vortex separator and a screen filter. The combination enhances the effectiveness of both methods at a lower cost than two separate filtration devices.

When water enters the filter the Spin Plate increases velocity and directs the flow into multiple spiral jets. The spiral action uses centrifugal force to separate heavy and medium weight particles to the outer edge of the filter barrel and down along the inside of the screen into the debris basin. The downward spiral flow action also picks up lighter particles too large to pass through the screen forcing them down into the debris basin. Thus, providing vortex separation and decreasing or eliminating the need for manual screen cleaning.

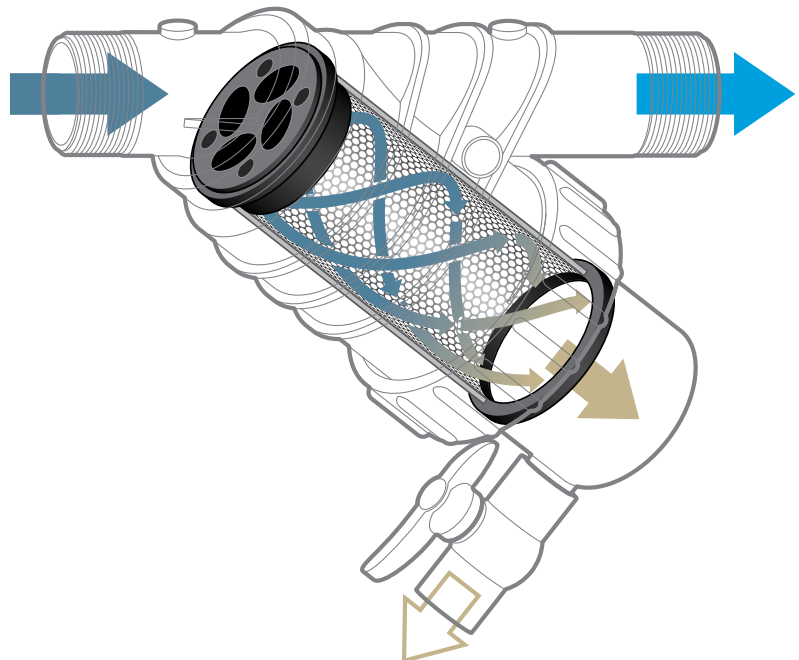

Manual periodic purging with the standard ball valve is the common method of keeping the filter clean and working. With higher particle loads operators often keep the ball valve partially or even fully open to continually purge accumulating debris from the debris basin. If a hose or pipe is used to direct the flow away from the ball valve it is important not to run up hill, long lengths or restrict the flow unnecessarily. It is best to discharge to atmosphere and gravity conveyance to a re-use sump.

## Important for Best Operation

**Use the proper size and number of jets.** The jets control the velocity of the vortex, which is critical for proper screen cleaning. The Spin Plates have multiple angled orifices (nozzles) that induce the downward spiral jets. Neither the Spin Plate nor the screen rotates. There are no moving parts which gives the Spin Clean a dependable, low maintenance, long life. To assure proper spiral action the correct Spin Plate and number of working nozzles should be sized per the flow rate. The number of active nozzles is controlled by plugging inactive nozzles with the provided plugs. For heavy particle loads some specifiers over size the Spin Clean body but use the Spin Plate from a smaller model and plugs per the design flow. The 1" and .75" spin plates can be used in either the 1" or .75" body. The 1.5" and 2" spin plates can be used in either the 1.5" or 2" body. This provides additional screen area but maintains the proper jet velocities. Please see this brochure for sizing and number of active nozzles recommended for your flow rate.

**The Spin Clean orientation.** The through pipe shall be orientated horizontally with the screen barrel and debris basin plumb and below the through pipe. The Spin Clean shall be installed in the pipe line with the "Y" end facing downstream. Height above grade and clearances shall be as shown in this brochure to allow removal of the debris basin and screen for periodic inspection and maintenance.

**The Spin Clean requires pressure to operate, like all hydraulic devices.** The designer shall provide at minimum, the desired downstream pressure plus the clean screen differential pressure shown in this brochure for the selected Spin Clean size and flow, at the inlet to the Spin Clean. The pressure differential will increase as the Spin Clean screen accumulates debris. It is common to double the clean screen differential when calculating overall system pressure requirements if not continually purging. This will allow the screen to continue to operate effectively as it accumulates debris, in-between purges.

For convenience, in addition to the needed internal components, the standard Spin Clean comes with; one manual purge valve, Spin Plate plugs, and Schrader port option.

## Maintenance

Care should be taken to keep the operating pressure differential across the filter between 5-8 psi. Pressure reading should be monitored sufficiently to detect any build up of pressure differential during normal operation, which indicates the start of filter screen plugging. When this occurs, the system should be shut down, the filter drained and disassembled. The screen element should be washed thoroughly using a high pressure spray washer, spraying from outside in.

### Steps to extend maintenance intervals:

1. Start with a thoroughly clean screen element. Rinsing with garden hose pressure is not as good as using a pressure washer.
2. Make sure the filter never runs with less than a 5 psi differential.
3. Change spin plates or use more Flow Inserts to boost operating differential to 8 psi if not already achieved, to further increase cleaning action.
4. Increase flush flow rate for continuous flushing filters.
5. Pre-screen heavy organic/aquatic loads with a self cleaning intake screen for surface water installations.
6. Open flush valve fully on start-up to prevent sudden loading from a surge of contaminants.

## 3/4" & 1" Filter Specifications

- Available with threaded cap or ball valve for flushing debris basin
- ABS models rated to 80 psi
- Engineered plastic models rated to 150 psi
- BSP thread available



### 3/4" Filter

- 3/4" MPT inlet x 3/4" MPT outlet
- Large screen area provides 23.4 sq. in. of filtration surface
- Maximum recommended flow is 11 gpm



### 1" Filter

- 1" MPT inlet x 1" MPT outlet
- Large screen area provides 23.4 sq. in. of filtration surface
- Maximum recommended flow is 20 gpm

## 1 1/2" & 2" Filter Specifications

- Standard with Ball Valve (Schedule 40 PVC)
- Filter screens are bonded to a perforated stainless steel outer case to prevent collapse
- Molded of high-strength engineered plastic and pressure rated to 150 psi
- BSP thread available



### 1 1/2" Filter

- 1 1/2" MPT inlet x 1 1/2" MPT outlet
- Maximum recommended flow is 55 gpm



### 2" Filter

- 2" MPT inlet x 2" MPT outlet
- Maximum recommended flow is 120 gpm



Jain is a fully integrated global food / plant production company recognized by Harvard Business to be one of five global sustainability champions, the G-20 for lifting people out of poverty, and Fortune magazine for being a "Change the World Company." Our irrigation manufacturing capabilities include everything from behind the pump to the flush valve at the end of the lateral and everything in between. We lead the industry in manufacturing technology, owning both our extrusion and mold manufacturing equipment providers.

Jain leads plant science research globally across a variety of food crops and is staffed with some of the world's leading research scientists. With the Gandhi Library, Jain now houses the leading collection of the world's best plant science knowledge in a single facility. Our agronomic knowledge is integrated from our world class plant tissue culture operations through our food processing businesses. We research, educate, advance, manufacture, finance, propagate plants, and purchase produce for processing all in an effort to fulfill the Jain mission:

**"Leave This World Better Than You Found It"**

**Jain Irrigation, Inc.**

[www.jainsusa.com](http://www.jainsusa.com)

**Jain Customer Service**

Phone: (559) 485-7171

Fax: (800) 777-6162

**Jain Corporate Office**

5965 S 900 E

Murray, UT 84121

**Western Manufacturing Facility**

2851 E. Florence Ave.

Fresno, CA 93721

**Northeastern Manufacturing Facility**

740 Water St.

Watertown, NY 13601