



Tonnellerie Rousseau

FR360° : THE ROTATIVE CASK

TECHNICAL CHARACTERISTICS

FR360° is a French oak round cask, customizable with your selection of accessories and positioned on a special oak stand with bearings.

This new product brings together noble raw material, technical accessories and the cooperage expertise, with an innovative side.

The stand has been designed for casks up to 12Hl. It is equipped with **stainless steel bearings** to facilitate the swinging and rotative movements. Thanks to this discrete and efficient system, it only takes one person to effortlessly make the cask rotate 360°.

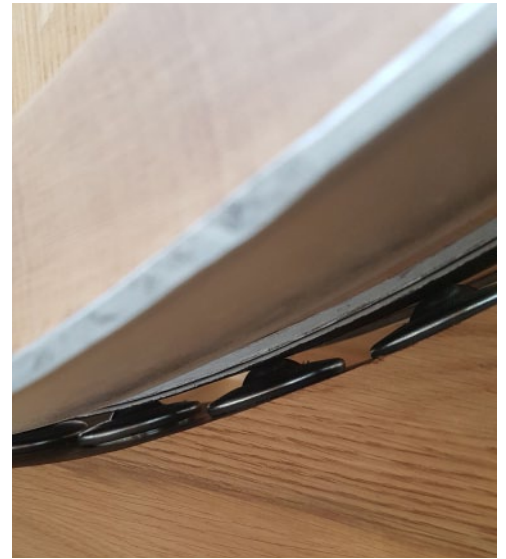

ORGANOLEPTIC ADVANTAGES

* No pumping or manipulations which may over age wines too quickly. Limited oxidation compared to open tanks.

White wines :

- * Batonnage is made easy and efficient, without bringing air in.
- * Fruitiness and color intensity are preserved, complex aromas are fostered.

Red wines :

- * Fermentation in the cask is made possible by adding a cupola lid : phenolic compounds are extracted and spread in a soft and homogeneous way.
- * Submerging the cap is made easy by simply rotating the cask – no punch down or pumping over.
- * Better integration of wood and tanins.



PRACTICAL ADVANTAGES

- * SS ball bearings to rotate the cask 360°
- * Customized cask
- * Customized stands to fit your forklift
- * Handles to ease the rotation
- * Easy washing and drainage

DESIGN ADVANTAGES

- * A discrete system fully integrated in the stand
- * Laser etching of your logo at the front
- * Oak stand with SS protection

OPTIONS

Flush-mounted door, oval door, cupola lid, draining valve, racking valve, taster, thermometer, thermowell, adjustable SS feet.

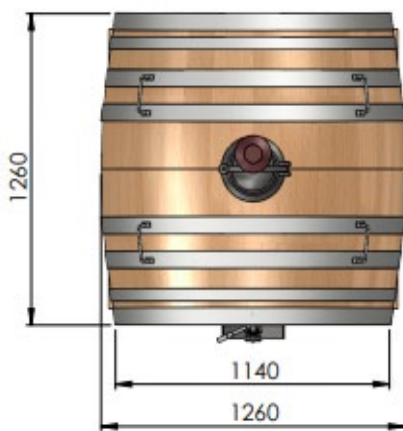

B1-51
BILLE PORTEUSE MASSIVE
(B1-51-30)

